

# ENGINEERING DATA



Smith &  
Loveless, Inc.®

14040 West Santa Fe Trail Drive  
Lenexa, Kansas 66215-1284

2-Pump Classic Wet Well  
Mounted Pump Station  
Section Index  
July, 2012  
Page 1 of 2

## 2-PUMP CLASSIC WET WELL MOUNTED PUMP STATION SECTION INDEX

DESCRIPTION	DATE	PAGE
<b>Design Factors</b>		
• Station Friction Loss	July, 2012	1
<b>2 – PUMP STATION</b>		
• 2-Pump Classic Wet Well Mounted Pump Station Specification	July, 2012	1 – 18
• Standard 2-Pump WWMPs Electrical Service Data	July, 2012	1
<b>Outline Drawings</b>		
• 4B2C Pump – 4” Piping	87C411	
• 4B2C Pump – 6” Piping	87C412	
• 4B2B / 4B2D / 4B2X / 4C2C / 4C2D / 4C2X – 4” Piping – Model S	87C405	
• 4B2B / 4B2D / 4B2X / 4C2C / 4C2D / 4C2X – 6” Piping – Model S	87C406	
• 4B3B / 4C3C / 4D3B – 4” Piping – Model S	87C407	
• 4B3B / 4C3C / 4D3B – 6” Piping – Model S	87C408	
• 4D4B Pumps – 4” Piping – 6” x 4” x 4”	87B335	
• 4D4B Pumps – 6” Piping – 6” x 6” x 6”	87B336	
• 6B3_ / 6C3_ / 6D3_ – 6” Piping – Model S – 6” x 6” x 6” Piping	87C409	
• 6B3_ / 6C3_ / 6D3_ – 6” Piping – Model S – 8” x 6” x 8” Piping	87C410	
• 2-Pump Classic WWMPs Wiring Diagram	87B515	
• 8C4D / 8D4D Pumps – 8” Piping, 8” Suction, 8” Discharge	87C344	
• 8C4D / 8D4D Pumps – 8” Piping, 10” Suction, 10” Discharge	87C345	

# ENGINEERING DATA



Smith &  
Loveless, Inc.®

14040 West Santa Fe Trail Drive  
Lenexa, Kansas 66215-1284

2-Pump Classic Wet Well  
Mounted Pump Station  
Section Index  
July, 2012  
Page 2 of 2

## Outline Drawings (Continued)

- 8C4D / 8D4D Pumps – 10” Piping, 10” Suction, 10” Discharge 87C362
- 8C4D / 8D4D Pumps – 10” Piping, 12” Suction, 10” Discharge 87C375
- 8C4D / 8D4D Pumps – 10” Piping, 12” Suction, 12” Discharge 87C363
- 8C4D / 8D4D Pumps – Large Wet Well Installation 87C347
- 8D4V Pumps, 10” Piping, 10”/12”/14” Suctions, 10”/12” Discharge 87B648

# ENGINEERING DATA



Smith &  
Loveless, Inc.®

14040 West Santa Fe Trail Drive  
Lenexa, Kansas 66215-1284

Wet Well Mounted  
Pump Station  
Station Friction Loss  
Design Factors  
July, 2012  
Page 1

## DESIGN FACTORS WET WELL MOUNTED PUMP STATIONS STATION FRICTION LOSS

2-PUMP STATIONS 4" PIPING		2-PUMP OR 3-PUMP STATIONS 6" PIPING				LARGE 2-PUMP STATIONS			
GPM	FEET	GPM	FEET	GPM	FEET	8" PIPING		10" PIPING	
GPM	FEET	GPM	FEET	GPM	FEET	GPM	FEET	GPM	FEET
100	0.5	100	0.1	800	5.5	400	0.6	800	1.0
150	1.2	200	0.3	900	7.0	600	1.2	1000	1.4
200	2.0	300	0.5	1000	8.5	800	2.0	1200	2.0
250	3.2	400	1.5	1100	10.0	1000	3.0	1400	2.5
300	4.5	500	2.3	1200	12.0	1200 (3)	4.2	1600	3.2
350 (1)	6.0	600	3.2			1400	5.6	1800 (4)	4.0
400	7.6	700 (2)	4.3			1600	7.1	2000	5.0
						1800	9.0	2200	6.0
								2400	7.0

1. 350 GPM and above based on 6" suction lines.
2. 700 GPM and above based on 8" suction lines.
3. 1200 GPM and above based on 10" suction lines.
4. 1800 GPM and above based on 12" suction lines.

**NOTE:** Please refer to Pump Curves for recommended suction and discharge piping sizes.

# ENGINEERING DATA



Smith &  
Loveless, Inc.®

14040 West Santa Fe Trail Drive  
Lenexa, Kansas 66215-1284

2-Pump Classic Wet Well  
Mounted Pump Station  
Specification  
July, 2012  
Page 1

## SPECIFICATION CLASSIC WET WELL MOUNTED PUMP STATION WITH DUPLEX NON-CLOG PUMPS

### GENERAL

The contractor shall furnish and install one factory-built, automatic pumping station as manufactured by Smith & Loveless, Inc., Lenexa, Kansas. The station shall be complete with all needed equipment, factory-installed on a welded steel base with fiberglass cover.

The principal items of equipment shall include two vertical, close-coupled, motor driven, vacuum primed, non-clog pumps; valves; internal piping; central control panel with circuit breakers; motor starters and automatic pumping level controls; heater; ventilating blower; priming pumps with **SONIC START**® pump prime detection system and appurtenances; and all internal wiring.

### OPERATING CONDITIONS

Each pump shall be capable of delivering \_\_\_\_ GPM of raw water or wastewater against a total dynamic head of \_\_\_\_ feet. The minimum acceptable pump efficiency at this condition shall be \_\_\_\_%. Due to the energy conservation requirements, the minimum efficiency will be enforced. The maximum allowable speed shall be \_\_\_\_ RPM. The minimum rated horsepower of each pump motor shall be \_\_\_\_\_. The maximum static suction lift shall be \_\_\_\_ feet.

All openings and passages shall be large enough to permit the passage of a sphere 3" in diameter and the pump shall have a flanged suction and discharge connection no smaller than 4". The anticipated operating head range is from \_\_\_\_ feet minimum to \_\_\_\_ feet maximum. The pump motors shall not be overloaded beyond their nameplate rating at the design conditions nor at any head in the operating range.

### CONSTRUCTION

The station shall be constructed in one complete, factory-built assembly. It shall be sized to rest on the top of the wet well as detailed in the construction drawings. The supporting floor plate shall be minimum 3/8" thick steel with reinforcing, as required, to prevent deflection and ensure an absolutely rigid support. Steel plate shall meet or exceed ASTM A-36 specifications.

The pump station shall be enclosed by a hinged fiberglass cover made of molded reinforced orthophthalic polyester resins with a minimum of 30% glass fibers with a minimum average length of 1-1/4". The outside of the enclosure shall be coated with a polyester protective in-mold coating for superior resistance to weathering, ultraviolet radiation, yellowing and chalking. The completed fiberglass enclosure shall be resistant to mold, mildew, fungus and corrosive liquids and gasses normally found in pump station environments. The dimensions of the enclosure shown on the drawings shall be considered a minimum, for internal component clearances and accessibility, and nothing smaller will be acceptable. The cover shall have a suitable drip-lip around the edge and shall be provided with a hasp and staple connection to the floor plate to allow the pump chamber to be locked with a padlock.

The cover shall be attached with a multi segment stainless steel hinge, constructed of 7 gauge (minimum) type 304 stainless steel with a 3/8" diameter stainless steel pin and supporting at least 75% of the width of one end. Stainless steel bolts with tamperproof heads and a full width 3/8" thick anodized aluminum backing plate shall anchor the hinge to the fiberglass cover.

Dual high-pressure gas struts shall be provided to counteract the dead weight of the cover assembly and limit the maximum lifting force required for opening to less than 20 pounds. The cover shall be self-latching upon opening, with a manually operated release for closing. Duplex heavy gauge safety chains shall be provided to prevent over-extension. All hardware and components of the cover assembly that are exposed to the weather shall be constructed of corrosion-resistant materials.



# ENGINEERING DATA



Smith &  
Loveless, Inc.®

14040 West Santa Fe Trail Drive  
Lenexa, Kansas 66215-1284

2-Pump Classic Wet Well  
Mounted Pump Station  
Specification  
July, 2012  
Page 2

Heavy extruded aluminum, adjustable ventilating louvers shall be provided on each end of the fiberglass cover, which are capable of being closed during cold weather operation.

An aluminum manway cover fabricated of 1/4" treadplate, located exterior to the fiberglass pump chamber shall be provided, complete with padlocking provisions. The manway shall be an integral part of the station floor plate and provide access to the wet well. The minimum open area of the manway access into the wet well shall be at least 4.2 square feet.

The manway cover shall have a three color 7" x 10" (minimum) corrosion-resistant sign permanently affixed to it, reading "DANGER – Before Entering, Test For Explosive Gases. Test For Oxygen Deficiency. Supply Fresh Air To Work Area".

Enclosures utilized to house the valve train and/or controls, which are defined under OSHA Article 29CFR, Parts 1910 as a Confined Space shall not be acceptable.

To allow on-site maintenance of the pumps, a stanchion with lifting arm shall be provided to lift each pump. The lifting arm shall have a hook over the center of the motor to support a hoist (provided by others) for removal of the motors, impellers and pumps from the station.

The pump casings and discharge piping shall be mounted in relation to the floor plate as detailed in the construction drawings. The suction and discharge connections, where they pass through the floor shall be sealed by gaskets, rather than being welded, to allow adjustment and replacement.

## **☐ DURO-LAST® CORROSION-RESISTANT STAINLESS STEEL BASEPLATE [OPTIONAL ITEM. DESIGNER CHECK IF REQUIRED]**

The baseplate of the pump station structure shall be fabricated of corrosion-resistant lean duplex series 2100 stainless steel alloy, 316L stainless steel or equal. The stainless steel shall have a Pitting Resistance Equivalent Number (PRE<sub>N</sub>) of 24.0 or greater and general corrosion resistance shall be less than or equal to 0.1 mm per year in 15% H<sub>2</sub>SO<sub>4</sub> at 120 degrees F. Due to the corrosion resistance requirements, Grade 304-304L is not acceptable.

The stainless steel surfaces shall be glass bead blast cleaned to remove surface contamination and provide a uniform finish.

The manufacturer of the station shall warrant the stainless steel baseplate for twenty-five (25) years from date of shipment against structural failure and perforation due to corrosion.

## **WELDING**

All steel structural members shall be joined by electric arc welding with welds of adequate section for the joint involved. Structural welding shall be preformed in accordance with AWS standards and procedures.

## **PROTECTION AGAINST CORROSION**

All structural steel surfaces shall be factory blasted with steel grit, in an environmentally controlled booth, to remove rust, mill scale, weld slag, etc. Sandblasting is specifically prohibited. All weld spatter and surface roughness shall be removed by grinding. Surface preparation shall comply with SSPC-SP6 specifications. Immediately following cleaning, a single 6-mil dry film thickness of **VERSAPOX®**, a self-priming Cycloaliphatic Amine Epoxy, shall be factory applied. This coating shall be as formulated by Smith & Loveless for abrasion and corrosion resistance.

Stainless steel, aluminum and other corrosion-resistant surfaces shall not be coated. Carbon steel surfaces not otherwise protected shall be coated with a suitable non-hardening rust preventative compound. Auxiliary components such as the electrical enclosure, ventilating blower and vacuum pumps shall be furnished with the original manufacturer's coating.

Finish coating shall be accomplished prior to shipment of the station from the factory and shall comply fully with the intent of these specifications. A touch-up kit shall be provided by the pump station manufacturer for repair of any mars or scratches occurring during shipping and installation. This kit shall contain detailed instructions for use and shall be the same material as the original coating.

# ENGINEERING DATA



Smith &  
Loveless, Inc.®

14040 West Santa Fe Trail Drive  
Lenexa, Kansas 66215-1284

2-Pump Classic Wet Well  
Mounted Pump Station  
Specification  
July, 2012  
Page 3

## MAIN PUMPS

The pumps shall be (4") (6") (8") vertical, centrifugal non-clog type of heavy cast-iron construction, especially designed for the use of mechanical seals and vacuum priming. In order to minimize seal wear caused by linear movement of the shaft, the shaft bearing nearest the pump impeller shall be locked in place so that endplay is limited to the clearance within the bearing. To minimize seal wear resulting from shaft deflection caused by the radial thrust of the pump, the shaft from the top of the impeller to the lower bearing supporting the impeller shall have a minimum diameter of 1-7/8" for motor frame sizes 213 through 286; 2-1/8" for motor frame sizes 324 and 326; and 3" for frame 364 and larger. The dimension from the lowest bearing to the top of the impeller shall not exceed 6". The motor shaft shall be directly connected to the impeller without the use of drive belts or couplings, which require alignment and maintenance, and which increase power consumption due to their inherent energy losses.

Pumps with less than a standard 4" suction or 4" discharge connection, or with less than a 3" spherical solids handling capacity will be rejected for this application.

The oversized shaft incorporating oversized bearings and heavier bearing frame construction provides for extended mechanical seal, bearing and overall pump/motor life. Since the larger shaft with the specified minimum overhang is the key to heavier, more rigid construction throughout, no deviation from the specified shaft diameter or tolerances will be allowed.

The bearing nearest the impeller shall be designed for the combined thrust and radial load. The upper bearing shall be free to move in a linear direction with the thermal expansion of the shaft and shall carry only radial loads.

The shaft shall be solid stainless steel through the mechanical seal to eliminate corrosion and abrasive rust particles. Removable shaft sleeves will not be acceptable if the shaft under the sleeve does not meet the specified minimum diameter.

The pump shall have an integral adapter providing a large water reservoir above the impeller to provide for positive exclusion of air from the impeller. The seal shall be inside this area to assure lubrication. Pumps which do not use hollow priming adapters for positive lubrication of the seal will not be acceptable. Self-priming pumps are specifically unacceptable due to the need for suction check valves, air vent piping and the possibility of overheating and damaging the pump or producing steam or high temperatures in the pump, which may be a hazard to the operator, when the pump is run dry. The pump controls must be set so that the main pumps cannot be turned on unless they are filled with liquid, and the pump is completely primed.

The pump shall be constructed so as to permit priming from the lower pressure area behind the impeller. Priming from high-pressure connections, which tends to cause solids to enter and clog the priming system, will not be acceptable. The priming bowl shall be transparent, enabling the operator to monitor the priming level.

The pump shall be arranged so that the rotating element can easily be removed from the casing without disconnecting the electrical wiring or disassembling the motor, impeller, backhead or seal, so that any foreign object may be removed from the pump or suction line. Enclosed impellers must be used to avoid the necessity of wear plates and the associated costs of replacement and maintenance of wear plate clearances with semi-open impellers.

The pump shaft shall be sealed against leakage by a single mechanical seal constructed so as to be automatically drained and primed each time the pump is drained and primed. Water, which lubricates the mechanical seal, shall be automatically drained from around the seal if the pump loses prime in order to allow both the pump and the seal to be drained, thereby preventing freezing and breakage of the seal during power outages in sub-freezing temperatures.

The seal shall be of carbon and ceramic materials with the mating surfaces lapped to a flatness tolerance of one light band. The rotating ceramic shall be held in mating position with the stationary carbon by a stainless steel spring. The entire seal assembly shall be held in place by a bronze seal housing to prevent excessive heat buildup. Use of cast-iron or other ferrous material for the seal housing which will rust and damage the seal, shortening its life, will not be acceptable.

The pump volute shall be furnished with mounting lugs and bolted to the station floor plate, forming a gas-tight seal.

# ENGINEERING DATA



Smith &  
Loveless, Inc.®

14040 West Santa Fe Trail Drive  
Lenexa, Kansas 66215-1284

2-Pump Classic Wet Well  
Mounted Pump Station  
Specification  
July, 2012  
Page 4

**[NOTE TO DESIGNER: SELECT ONE OF THE FOLLOWING PUMP TYPE PARAGRAPHS, A OR B, AND DELETE THE OTHER. CHECK PUMP CURVES FOR PROPER APPLICATION]**

## **A. NON-CLOG TWO-PORT IMPELLER (4", 6", 8" PUMP OPTION)**

The pump impeller shall be of the enclosed two-port type made of close-grained cast-iron and shall be balanced. The eye of the impeller as well as the ports shall be large enough to permit the passage of a sphere 3" in diameter in accordance with nationally recognized codes. The impeller shall be keyed with a stainless steel key and secured to the motor shaft by a stainless steel capscrew equipped with a Nylock or other suitable self-locking device. The impeller shall not be screwed or pinned to the motor pump shaft and shall be readily removable without the use of special tools. To prevent the buildup of stringy materials, grit and other foreign particles around the pump shaft, all impellers less than full diameter shall be trimmed inside the impeller shrouds. The shrouds shall remain full diameter so that close minimum clearance from shrouds to volute is maintained. Both the end of the shaft and the bore of the impeller shall be tapered to permit easy removal of the impeller from the shaft.

## **B. X-PELLER® SUPER CLOG-RESISTANT MONO-PORT IMPELLER (4" & 6" PUMP OPTION)**

The pump impeller shall be of the enclosed mono-port type made of close-grained cast-iron and shall be in dynamic balance when pumping wastewater. Two port impellers are specifically disallowed. The dynamic balance shall be obtained without the use of balance weights or liquid filled chambers. The impeller shall be designed to allow for the trimming of the impeller to meet design condition changes without altering the balance. The eye of the impeller as well as the port shall be large enough to permit the passage of a sphere 3" in diameter in accordance with nationally recognized codes. To further prevent clogging, the impeller port shall have a minimum area of 10.6 in<sup>2</sup>. The impeller shall be keyed with a stainless steel key and secured to the motor shaft by a stainless steel capscrew equipped with a Nylock or other suitable self-locking device. The impeller shall not be screwed or pinned to the motor pump shaft and shall be readily removable without the use of special tools. To prevent the buildup of stringy materials, grit and other foreign particles around the pump shaft, all impellers less than full diameter shall be trimmed inside the impeller shrouds. The shrouds shall remain full diameter so that close minimum clearance from shrouds to volute is maintained. Both the end of the shaft and the bore of the impeller shall be tapered to permit easy removal of the impeller from the shaft.

## **MOTORS**

The pump motors shall be vertical, solid shaft, NEMA P-base, squirrel-cage induction type, suitable for \_\_\_\_\_ phase, \_\_\_\_\_ cycle, \_\_\_\_\_ volt electric current. They shall have Class F insulation. Insulation temperature shall, however, be limited to Class B. The motors shall have normal starting torque and low-starting current, as specified by NEMA Design B characteristics. They shall be open drip-proof design with forced air circulation by integral fan. Openings for ventilation shall be uniformly spaced around the motor frame. Leads shall be terminated in a cast connection box and shall be clearly identified.

The motors shall have 1.15 service factor. The service factor shall be reserved for the owner's protection. The motors shall not be overloaded beyond their nameplate rating, at the design conditions, nor at any head in the operating range as specified under Operating Conditions.

The motor-pump shaft shall be centered, in relation to the motor base, within .005". The shaft runout shall not exceed .003".

The motor shaft shall equal or exceed the diameter specified under Main Pumps at all points from immediately below the top bearing to the top of the impeller hub.

A bearing cap shall be provided to hold the bottom motor bearing in a fixed position. Bearing housings shall be provided with fittings for lubrication as well as purging old lubricant.

The motor shall be fitted with heavy lifting eyes or lugs, each capable of supporting the entire weight of the pump and motor.

# ENGINEERING DATA



Smith &  
Loveless, Inc.®

14040 West Santa Fe Trail Drive  
Lenexa, Kansas 66215-1284

2-Pump Classic Wet Well  
Mounted Pump Station  
Specification  
July, 2012  
Page 5

**[NOTE TO DESIGNER: CHOOSE FROM THE FOLLOWING MOTOR OPTIONS, IF REQUIRED. DELETE IF NOT REQUIRED]**

## **A. SUPER DUTY MOTORS**

The pump motors shall be Premium Efficiency type, per NEMA MG-1 table 12-12, Inverter Ready per NEMA Part 31.4.4.2, with cast-iron frames, and be UL Recognized and CSA Approved. The motor windings shall be 200 C Inverter Spike-Resistant magnet wire and the rotors shall have an epoxy coating for corrosion protection.

## **B. IMMERSIBLE PUMP MOTORS**

The pump motors shall be of special construction and fitted with special seals to enable the motor to be immersed in up to 30' of water for a period of up to three weeks, without water entering the motor cavity. As part of the immersible motor package, a float switch shall be provided in the station to provide indication of water approaching the level of the motors and another float switch shall shut down the motors when the water level reaches them. Each of these floats shall signal alarms and activate alarm lights on the control panel. The alarms shall remain activated until manually reset by switches on the panel. In addition, moisture detectors and high temperature thermostats shall be provided in each motor, as a backup, to shut down the associated pump and to signal alarm conditions and activate alarm lights on the control panel. All of these alarm contacts shall be wired to a terminal strip in the control panel for connection to the Owner's alarm system.

## **CONTROLS**

The control equipment shall be mounted in a NEMA Type 1 steel enclosure with a hinged access cover. The circuit breakers and control switches shall be operable without opening the access cover.

A grounding-type convenience outlet shall be provided on the side of the cabinet for operation of 120-volt AC devices.

Thermal magnetic air circuit breakers shall be provided for branch disconnect service and short circuit protection of all motor control and auxiliary circuits.

Magnetic across-the-line starters with under-voltage release and overload coils for each phase shall be provided for each pump motor to give positive protection. Each single-phase auxiliary motor shall be equipped with an over-current protection device in addition to the branch circuit breaker, or shall be impedance protected. All switches shall be labeled and a coded wiring diagram shall be provided.

**[NOTE TO DESIGNER: SELECT ONE OF THE FOLLOWING LEVEL CONTROL SYSTEM PARAGRAPHS, A OR B, AND DELETE THE OTHER.]**

## **A. FLOAT SWITCH LEVEL CONTROLS**

To control the operation of the pumps with variations of liquid level in the wet well, a minimum of three (3) displacement switches shall be provided. A 30' cord shall be provided with each switch. The cord shall have a corrosion-resistant vinyl jacket and be multi-stranded in order to prevent fatigue.

An automatic alternator with manual switch shall be provided to change the sequence of operation of the pumps every eight hours. Alternating the pumps at less than eight-hour intervals will not be acceptable.

Provisions shall also be made for the pumps to operate in parallel should the level in the wet well continue to rise above the starting level for the low level pump.

## **B. PumpLogix™ MICROPROCESSOR LEVEL CONTROL SYSTEM**

The liquid level in the wet well shall be monitored by a submersible hydrostatic pressure transducer with stainless steel sensor diaphragm, providing a 4-20 mA signal to the pump control unit. The body of the transducer shall be made of 316 stainless steel. The pressure transducer shall have a permanent hermetically sealed connection to a polyethylene insulated

# ENGINEERING DATA



Smith &  
Loveless, Inc.®

14040 West Santa Fe Trail Drive  
Lenexa, Kansas 66215-1284

2-Pump Classic Wet Well  
Mounted Pump Station  
Specification  
July, 2012  
Page 6

cable, which shall support the transducer 6" from the bottom of the wet well, and shall pass through a cord grip seal in the station base. The pressure transducer unit shall be rated for wastewater or potable water service, and for operation in explosion hazardous areas.

Three (3) displacement switches shall be provided to automatically operate the pump in back-up mode, in case of failure of the digital control system or the submersible level transducer. The back-up system shall be entirely independent of the digital system. A 30' color-coded cord shall be provided with each switch. The cord shall have a corrosion-resistant vinyl jacket and be multi-stranded in order to prevent fatigue. The displacement switch cords and the cable for the submersible pressure transducer shall enter the wet well through cord grip seals.

To control the operation of the pumps with variations of liquid level in the wet well, and the high and low water alarm functions, a specially preprogrammed, dedicated microprocessor-based control system shall be provided. The controller shall interface with the wet well level transducer, integral panel display unit, motor starters, and alarm functions as required.

The digital controls shall operate on 24 volts or less, to eliminate shock hazard. The 24-volt power supply shall be overload protected to be "crowbar safe" and will return to operation when a short is removed.

To reduce exposure to corrosive environments and ensure the control system's reliable, long-term operation, the controller shall have a sealed, user-friendly, graphical interface. The interface shall be comprised of a rotary knob, switches and five (5) columns of ultra-bright, daylight-viewable red LED's. Four (4) 40-segment, 4" columns of LED's shall show the wet well level, the pump on and off control bands, and the high and low alarm setpoint bands. All LED's within a control band shall be illuminated when operating under normal power. A fifth LED column shall indicate the controller's configuration, status, and active alarms. Alarms shall consist of high alarm, low alarm and input signal out of range. Monitor functions shall include control power and normal system operation. Discrete LED's shall show the activation of the differential pump control stages.

The controller shall provide easy, convenient indication and adjustment of the operating setpoints and controller configuration without the need for tools. For ease of operation and configuration, multiple indicating columns are required. Controllers that provide fewer columns; thus, limiting the viewing of relevant and necessary station information, are specifically precluded by this specification.

The pump control circuits shall be forced OFF by power loss. Upon power restoration, the controller shall enable the pumps in an adjustable time-step sequence as required to meet the demand.

The controller shall continuously indicate the status of the selected alternation sequence and control modes. The controller shall provide 1<sup>st</sup> On/1<sup>st</sup> Off, Fixed and Auto Rotate alternation sequences.

Integral span, offset, and damping adjustments shall be easily adjustable. The controller shall have a configurable security lockout feature.

The controller shall contain a level simulation function that allows manual manipulation of the displayed process variable. While simulating, the controller shall display both the actual wet well level and the simulated level.

The controller shall contain an RS-232 communication port and have capabilities for connection to a SCADA (Supervisory Control and Data Acquisition) system using Modbus® protocol. The complete assembly shall be designed for use in UL508 Industrial Control Panels.

It is the specific intention of this functional requirement that a controller shall be provided with features as described herein. Additionally, this controller shall be a fully integrated assembly. That is, the furnishing of similar functions using multiple setpoint modules, a custom-configured programmable logic controller (PLC) or extensive relay/timer logic to accomplish control sequences, etc., is specifically precluded by this specification and is not acceptable.

Provisions shall also be made for the pumps to operate in parallel should the level in the wet well continue to rise above the starting level for the low level pump.



# ENGINEERING DATA



Smith &  
Loveless, Inc.®

14040 West Santa Fe Trail Drive  
Lenexa, Kansas 66215-1284

2-Pump Classic Wet Well  
Mounted Pump Station  
Specification  
July, 2012  
Page 7

## HIGH WET WELL LEVEL ALARM

An adjustable displacement switch shall be provided to sense a high water level condition. The switch shall hang into the wet well and shall activate a contact to indicate the high water condition.

## RUNNING TIME METER

A running time meter shall be supplied for each pump to show the number of hours of operation. The meter shall be enclosed in a dust and moisture-proof molded plastic case. The flush-mounted dial shall register in hours and tenths of hours up to 99,999.9 hours before repeating. The meter shall be suitable for operation from a 115-volt, 60-cycle supply.

## PUMP FAILURE TO PRIME OR FAILURE TO PUMP ALARM (CHECK VALVE SWITCH TYPE)

To sense failure to deliver normal flow for any reason, including failure to prime, each pump shall be provided with a sealed sensor switch mounted in a protective ABS enclosure. The enclosure shall be mounted with an adjustable universal mounting bracket to the external arm of each discharge check valve. The mounting bracket shall allow the adjustment of the sensor switch with a single locking pivot adjustment. A red LED indicating light shall be provided on each switch unit to facilitate accurate setting of the switch for proper operation. The sensor switch shall monitor the movement of the check valve arm and thereby detect failure of the pump to deliver normal operating flow when called on to run. An auxiliary time delay relay shall be provided to prevent an alarm signal during the pump priming and startup period.

### (OPTIONAL ITEM – CHECK IF REQUIRED)

### **SINGLE-PHASE 120-VOLT POWER TRANSFORMER PACKAGE [DESIGNER: SELECT IF SEPARATE 120-VOLT SUPPLY IS NOT AVAILABLE. ALSO SELECT 2, 3 OR 5 KVA SIZE]**

<u>Suction Pipe Size</u>	<u>Aux. Heater</u>	<u>Min. Transformer Size</u>
4"	No	3 KVA 208v
4"	No	2 KVA 230/460v
4"	Yes	3 KVA 208/230/460v
6" or 8"	No	5 KVA 208/230/460v
6" or 8"	Yes	5 KVA 208/230/460v

A (2) (3) (5) KVA insulating-type transformer shall be provided to supply power for lights, controls and auxiliary devices. The transformer shall have 240/480 volt primary, 120/240 volt secondary, Class F insulation, with temperature rise not to exceed 115°C above 40°C ambient. The core and coil assembly shall be given a double dip and bake. The coil shall be protected by a metal housing to prevent damage. The transformer shall be protected by a separate circuit breaker on the supply side.

## VACUUM-PRIMING SYSTEM

A vacuum priming system shall be furnished to prime the main pumps. The system shall be as shown on the vacuum priming schematic and shall include two vacuum pumps, providing 100 percent standby. Vacuum pumps shall have corrosion-resistant internal components. The vacuum priming system shall be complete with large port vacuum control solenoid valves, **SONIC START**® prime level sensor, float-operated check valves to protect the vacuum pumps, and all necessary shut-off valves as shown on the piping schematic. The float-operated check valves shall have a transparent body for visual inspection. All hoses and tubing used in the priming system shall be at least 3/8" nominal diameter.

The solenoid valves used in the vacuum priming system shall be of the high flow, direct acting brass body type, with threaded ports, NBR seals and 300 Series stainless steel plunger, rod, plate and springs. The minimum orifice diameter shall be 5/16". The solenoid valves shall be UL Listed, with Class F coil rating and of suitable voltage and thermal capacity for the application.

Liquid level in the pump priming chamber shall be monitored by a **SONIC START**® resonant frequency liquid level probe.

# ENGINEERING DATA



Smith &  
Loveless, Inc.®

14040 West Santa Fe Trail Drive  
Lenexa, Kansas 66215-1284

2-Pump Classic Wet Well  
Mounted Pump Station  
Specification  
July, 2012  
Page 8

The probe shall be equipped with a piezoelectric drive and sensitive circuits to detect frequency shifts when the probe is covered by liquid. The probe shall be completely sealed and have a 316L stainless steel housing for corrosion resistance. It shall be provided with a wiring connector molded of PolyPhenylSulfone, an amorphous high performance thermoplastic for impact and chemical resistance. The probe shall have a plug-in connector to facilitate easy removal.

The **SONIC START**® probe shall be provided with light emitting diodes. This diagnostic tool shall indicate connectivity, prime status or a fault condition. Systems utilizing an electrode, mechanical means such as a float, or that require any type of electrical or moving parts inside the priming chamber, which may accumulate debris, short out, bind or fail will not be acceptable.

The priming system shall automatically provide positive lubrication of the mechanical seal each time a main pump is primed. To prevent excessive stoppage due to grease accumulation, no passageway in the priming system through which the pumped liquid must pass shall be smaller than the equivalent of a 2-1/2" opening.

The vacuum priming system shall have two field selectable modes of operation. In the "On-Demand" mode, the priming system will operate only after a pump is called on to run, and if it is not primed. Once primed, the pump will be allowed to run. In the "Constant Prime" mode, both pumps are kept primed continuously, and ready to start immediately when called for.

## ENVIRONMENTAL EQUIPMENT

A ventilating blower capable of delivering 250 CFM at 0.1" static water pressure shall be provided in order to remove the heat generated by continuous motor operation. The ventilating blower shall be turned on and off automatically by a preset thermostat. A heavy extruded aluminum louvered grille with adjustable openings shall cover the discharge of the blower. A similar grille shall be provided in the other end of the station enclosure for air intake. A 500-watt electric heater controlled by a preset thermostat shall be furnished. The heater shall be rigidly mounted in the station to prevent removal.

## MAIN PIPING

The pump suction shall be drilled and tapped for a 125-pound American Standard flange for easy connection of the suction riser. The discharge line from each pump shall be fitted with a clapper-type check valve and eccentric plug valve. Size, location and quantity of check valves and plug valves shall be as shown on the construction drawing. The check valve shall be of the spring-loaded type with external lever arm and an easily replaced resilient seat for added assurance against vacuum leaks. Check valves shall have stainless steel shaft with replaceable bronze shaft bushings and shall be sealed with an adjustable Teflon seal. Ball-type check valves are specifically unacceptable for this application. An operating wrench shall be provided for the plug valves.

Protrusions through the floor plate shall be gas-tight where necessary to effect sealing between the equipment chamber and the wet well. Bolted and sealed joints shall be provided at the pump casings or suction pipes in order to prevent corrosive, noxious fumes from entering the station. Welded joints that do not allow adjustment or replacement will not be considered for this application. The pump station manufacturer shall extend the suction and discharge connections below the floor plate at the factory so that field connections can be made without disturbing the gas-tight seals.

The manufacturer of the pump station shall provide a compression-type sleeve coupling for installation in the common discharge pipe.

The pump and pump station specifications and the following checklist must be met in total. There are many reasons for incorporating a good pump specification. For example, the stainless steel shaft with tapered impeller attachment is provided to minimize corrosion, extend seal life, and provide ease of impeller removal and seal replacement without use of a wheel puller. All items specified are for long life, durability and maintainability of the pumping equipment. Deviations from the pump specification will not be allowed.

The checklist is also provided to insure that the proper pumping system is provided to the owner.

# ENGINEERING DATA



Smith &  
Loveless, Inc.®

14040 West Santa Fe Trail Drive  
Lenexa, Kansas 66215-1284

2-Pump Classic Wet Well  
Mounted Pump Station  
Specification  
July, 2012  
Page 9

## FACTORY TESTS

All components of the pump station shall be given an operational test at the pump station manufacturer's facility to check for excessive vibration or leaks in the piping or seals, and to correct operation of the automatic control and vacuum priming systems and all auxiliary equipment. Installed pumps shall take suction from a deep wet well, simulating actual service conditions. The control panel shall undergo both a dry logic test and a full operational test with all systems operating.

Factory test instrumentation must include flow measuring with indicator; compound suction gauge; Bourdon tube-type discharge pressure gauge; electrical meters to measure amperes, volts, kilowatts and power factor; speed indicator; and a Vibrometer capable of measuring both amplitude and frequency.

## SPARE PARTS

A complete replacement pump shaft seal assembly shall be furnished with each pump station. The spare seal shall be packed in a suitable container and shall include complete installation instructions. A spare volute gasket and seal gasket shall be provided.

An instructional video presentation on the pump mechanical seal system in DVD format shall be included. The DVD shall contain a presentation on the following subjects: purpose and location of the mechanical seal, signs of a defective mechanical seal, how to remove the mechanical seal, troubleshooting seal failure causes, seal components, required tools, how to reinstall the seal and how to place the pump back into service. The video shall include footage of an actual seal replacement.

## INSTALLATION AND OPERATING INSTRUCTIONS

Installation of the pump chamber shall be done in accordance with the written instructions provided by the manufacturer.

Operation and maintenance manuals shall be furnished which will include parts lists of components and complete service procedures and troubleshooting guide.

## STARTUP

The Manufacturer shall provide the services of a factory-trained representative for a maximum period of one day on-site to perform initial startup of the pump station and to instruct the owners operating personnel in the operation and maintenance of the equipment.

## WARRANTY

The manufacturer of the station shall warrant for one (1) year from date of start-up, not to exceed eighteen (18) months from date of shipment, that the structure and all equipment he provides will be free from defects in material and workmanship. Warranties and guarantees of the suppliers of various components in lieu of a single source responsibility by the Manufacturer will not be accepted. The Manufacturer shall assume prime responsibility for the warranty of the station and all components.

In the event a component fails to perform as specified or is proven defective in service during the warranty period, the Manufacturer shall repair or replace, at his discretion, such defective part. He shall further provide, without cost, such labor as may be required to replace, repair or modify major components such as the steel structure, main pumps, main pump motors and main piping manifold. After start-up service has been performed, the labor to replace accessory items, such as the blower, priming pumps, alternator, etc., shall be the responsibility of others.

The repair or replacement of those items normally consumed in service, such as seals, grease, light bulbs, etc., shall be considered as part of routine maintenance and upkeep.

It is not intended that the Manufacturer assume responsibility for contingent liabilities or consequential damages of any nature resulting from defects in design, material, workmanship or delays in delivery, replacement or otherwise.

## MANUFACTURER'S INSURANCE

ALL EQUIPMENT MANUFACTURERS, either direct or subcontractors to the general or mechanical contractors, SHALL HAVE in effect at TIME OF BID, CONTRACT AWARD, CONTRACT PERFORMANCE, and WARRANTY TERM,



# ENGINEERING DATA



Smith &  
Loveless, Inc.®

14040 West Santa Fe Trail Drive  
Lenexa, Kansas 66215-1284

2-Pump Classic Wet Well  
Mounted Pump Station  
Specification  
July, 2012  
Page 10

PRODUCT AND COMPREHENSIVE LIABILITY INSURANCE, INCLUDING SUDDEN AND ACCIDENTAL POLLUTION COVERAGE in the amount of FIVE MILLION DOLLARS, \$5,000,000, through an insurance company with a minimum rating of A+ (SUPERIOR) XV according to the BEST'S INSURANCE REPORTS. All policies must be written on an OCCURRENCE BASIS. Policies written on a CLAIMS MADE BASIS are not acceptable. A typical CERTIFICATE OF INSURANCE attesting to the specified coverage issued by the responsible carrier naming the ENGINEER OF RECORD and the OWNER as ADDITIONAL INSURED must be presented to the named additional insured prior to contract award. A FAILURE TO COMPLY with this requirement BY THE BIDDER will require DISQUALIFICATION of the BID and CONTRACT AWARD.

## MANUFACTURED EQUIPMENT

### OPTION 1 (STANDARDIZATION) [DELETE THIS LINE FROM FINAL SPEC TEXT]

The specifications and drawings detail Smith & Loveless equipment and represent the minimum standard of quality for both equipment and materials of construction. The contractor shall prepare his bid on the basis of the particular equipment and materials specified for the purpose of determining the low bid.

The owner has standardized on the named equipment in order to optimize their operation, facilitate maintenance and safety programs, provide for interchangeability of costly equipment items, reduce stocking levels required for necessary spare parts and provide increased flexibility in the utilization of their pumping equipment. Equipment substitutions, since incompatible with the district's standardization program, will not be considered.

### OPTION 2 (BASE BID WITH BID SUBMITTAL) [DELETE THIS LINE FROM FINAL SPEC]

The specifications and drawings detail Smith & Loveless equipment and represent the minimum standard of quality for both equipment and materials of construction. The contractor shall prepare his bid on the basis of this equipment for the purpose of determining the low bid without consideration of a possible substitute. Substitution of other makes may be considered if the equipment proposed for substitution is superior or equal in quality and efficiency to the standards of quality named in the specifications and this is demonstrated to the satisfaction of the engineer. Contractors wishing to offer a deduct for substitute equipment shall include the following submittal information with their proposal.

## BID SUBMITTAL

This submittal shall include all necessary information for the proper determination of the acceptability of the proposed substitution and shall not necessarily be limited to the following.

- A. Complete description of the equipment, system, process, or function, including a list of system components and features, drawings, catalog information and cuts, manufacturer's specifications, including materials description.
- B. Performance data and curves, and horsepower requirements.
- C. Outside utility requirements, such as water power, air, etc.
- D. Functional description of any internal instrumentation and control supplied including list of parameters monitored, controlled, or alarmed.
- E. Addresses and phone numbers of nearest service centers and a listing of the manufacturer's or manufacturer's representatives' services available at these locations, including addresses and phone numbers of the nearest parts warehouses capable of providing full parts replacement and/or repair services.
- F. A list of five installations in the states where similar equipment by the manufacturer is currently in similar service; include contact name, telephone number, mailing address of the municipality or installation, engineer, owner, and installation contractor; if five installations do not exist, the list shall include all that do exist, if any.
- G. Detailed information on site, architectural, structural, mechanical, plumbing, electrical, and control, and all other changes or modifications to the design and construction work necessary to adapt the equipment or systems to the arrangement shown and/or functions described on the drawings and in the technical specifications. This shall include plan view and section sketches illustrating any additional space requirements necessary to provide the minimum adequate clear space within and around the equipment for operation and maintenance, as shown on the drawings and specified.
- H. All differences between the specifications and the proposed substitute equipment shall be clearly stated in writing under a heading of "differences".

# ENGINEERING DATA



Smith &  
Loveless, Inc.®

14040 West Santa Fe Trail Drive  
Lenexa, Kansas 66215-1284

2-Pump Classic Wet Well  
Mounted Pump Station  
Specification  
July, 2012  
Page 11

- I. Other specified submittal requirements listed in the detailed equipment and material specifications.
- J. A completed and signed copy of the "Pump Station Certification Affidavit" which follows.

## EVALUATION

Approval of the substitution to bid as an alternate shall in no way relieve the contractor from submitting the specified shop drawings for approval or complying fully with all provisions of the specifications and drawings.

If substituted equipment is accepted, the contractor shall, at his own expense, make any changes in the structures, piping, electrical, etc. necessary to accommodate the equipment. If engineering is required due to substitution of alternate equipment, the contractor shall pay for all engineering charges.

To receive final consideration, copies of the manufacturers' quotations for the equipment may be required to document the savings to the satisfaction of the engineer. It is the intent that the owner shall receive the full benefit of the savings in cost of equipment and the contractor's bid price shall be reduced by an amount equal to the savings. In all technical and other evaluations, the decision of the engineer is final.

## TYPICAL BID FORM

**(ADD TO BID FORM AS APPLICABLE TO ABOVE SELECTED OPTION]**

### OPTION 1

For reasons of standardization, bids shall be based on the named equipment. Alternate bids will not be allowed.

### OPTION 2

The bid shall be based on the named equipment. Alternate/substitute equipment may be offered as a deduct, provided all conditions of the "manufactured equipment" section are met.

Alternate/substitute manufacturer \_\_\_\_\_

Deduct \$ \_\_\_\_\_.

# ENGINEERING DATA



Smith &  
Loveless, Inc.®

14040 West Santa Fe Trail Drive  
Lenexa, Kansas 66215-1284

2-Pump Classic Wet Well  
Mounted Pump Station  
Specification  
July, 2012  
Page 12

## PUMP STATION CERTIFICATION AFFIDAVIT (Two-Port Impeller)

A submittal to the owner by manufacturers proposing alternate, unnamed pump stations will be required with their bid. Included in the submittal shall be detailed drawings and specifications on the proposed pump station. The bid submittal shall include the following completed checklist signed by an officer of the company.

	YES	NO
Close-coupled pump design - no motor to pump shaft coupling or drive belts		
Pump shaft diameter of _____ minimum through seal		
Full diameter impeller shrouds, top and bottom		
Stainless steel pump shaft with tapered shaft to impeller fit		
Maximum pump shaft overhang of 6" - lower bearing to impeller		
Bronze seal housing		
Minimum pump efficiency at design point of _____ GPM of _____ %		
Impeller eye and ports pass a 3" sphere		
Class F motor insulation with Class B max motor temperature rise and 1.15 service factor		
Motor shaft run-out 0.003" max at end of shaft		
Motor shaft centered to motor base with 0.005"		
Locked lower bearing and floating upper bearing		
One-piece motor adapter/backhead		
Motor HP of _____ at _____ RPM		
Complete pump station factory tested on a wet well		
Priming from low pressure area behind the impeller		
Resonant frequency pump prime detection system		
Transparent priming bowl for operator monitoring		
Hollow priming adapter for positive seal lubrication		
Completely separate priming system for each pump		
Minimum 2-1/2" equivalent opening in priming passageways		
Maximum 20 lb. Force required to open station cover		
All other items for the station, as specified with minimum sizes, capacities and materials indicated		
Product liability insurance, \$5 million per specification		
Structure blasted with steel grit in environmentally controlled booth prior to coating with epoxy resin		

The consulting engineer shall be the sole judge of whether the proposed equipment is acceptable. The manufacturer shall have the responsibility of submitting sufficient information in one submission. Incomplete or inaccurate submittal data shall be cause for rejection of the proposed equipment.

By signing this affidavit, the officer of the company has stated 100% compliance with the plans and specifications and further states he will supply or pay for all deficiencies found in the job submittals or after the unit is installed. The consulting engineer shall be the sole judge regarding compliance with the plans and specifications and shall be sole judge on the amount of moneys required if any deficiencies are found, related to, but not limited to, a 20-year station design life.

\_\_\_\_\_  
Signature of Company Officer

Corporate Seal  
(Notarized)

\_\_\_\_\_  
Title

# ENGINEERING DATA



Smith &  
Loveless, Inc.®

14040 West Santa Fe Trail Drive  
Lenexa, Kansas 66215-1284

2-Pump Classic Wet Well  
Mounted Pump Station  
Specification  
July, 2012  
Page 13

## PUMP STATION CERTIFICATION AFFIDAVIT (X-PELLER® Mono-Port Impeller)

A submittal to the owner by manufacturers proposing alternate, unnamed pump stations will be required with their bid. Included in the submittal shall be detailed drawings and specifications on the proposed pump station. The bid submittal shall include the following completed checklist signed by an officer of the company.

	YES	NO
Close-coupled pump design – no motor to pump shaft coupling or drive belts		
Pump shaft diameter of _____ minimum through seal		
Full diameter impeller shrouds, top and bottom		
Stainless steel pump shaft with tapered shaft to impeller fit		
Maximum pump shaft overhang of 6" - lower bearing to impeller		
Bronze seal housing		
Minimum pump efficiency at design point of _____ GPM of _____ %		
Impeller eye and port pass a 3" sphere		
Impeller of mono-port design with a minimum area of 10.6 square inches		
Trimming of impeller vane does not alter dynamic balance		
Impeller dynamically balanced without use of weights or liquid filled chambers		
Class F motor insulation with Class B max motor temperature rise and 1.15 service factor		
Motor shaft run-out 0.003" max at end of shaft		
Motor shaft centered to motor base with 0.005"		
Locked lower bearing and floating upper bearing		
One-piece motor adapter/backhead		
Motor HP of _____ at _____ RPM		
Complete pump station factory tested on a wet well		
Priming from low pressure area behind the impeller		
Resonant frequency pump prime detection system		
Transparent priming bowl for operator monitoring		
Hollow priming adapter for positive seal lubrication		
Completely separate priming system for each pump		
Minimum 2-1/2" equivalent opening in priming passageways		
Maximum 20 lb. force required to open station cover		
All other items for the station, as specified with minimum sizes, capacities and materials indicated		
Product liability insurance, \$5 million per specification		
Structure blasted with steel grit in environmentally controlled booth prior to coating with epoxy resin		

The consulting engineer shall be the sole judge of whether the proposed equipment is acceptable. The manufacturer shall have the responsibility of submitting sufficient information in one submission. Incomplete or inaccurate submittal data shall be cause for rejection of the proposed equipment.

By signing this affidavit, the officer of the company has stated 100% compliance with the plans and specifications and further states he will supply or pay for all deficiencies found in the job submittals or after the unit is installed. The consulting engineer shall be the sole judge regarding compliance with the plans and specifications and shall be sole judge on the amount of moneys required if any deficiencies are found, related to, but not limited to, a 20-year station design life.

\_\_\_\_\_  
Signature of Company Officer

\_\_\_\_\_  
Title

Corporate Seal  
(Notarized)



## **ADDITIONAL ACCESSORY OPTIONS [DESIGNER: SELECT AS REQUIRED]**

### **LOW WET WELL LEVEL ALARM**

An adjustable displacement switch shall be provided to sense a low water level condition. The switch shall hang into the wet well and shall activate a contact to indicate the low water condition.

### **RUNNING TIME METER FOR PARALLEL OPERATION**

A third running time meter shall be supplied to show the number of hours of operation with both pumps running in parallel. The meter shall be enclosed in a dust and moisture-proof molded plastic case. The flush mounted dial shall register in hours and tenths of hours up to 99,999.9 hours before repeating. The meter shall be suitable for operation from a 115-volt, 60-cycle supply.

### **PUMP RUNNING LIGHTS**

A green panel light to indicate "Pump On" shall be provided for each main pump.

### **120V ALARM LIGHT**

A vapor-proof light fixture with 50-watt lamp for outdoor pole mounting shall be provided with a red globe and guard.

### **120V ALARM LIGHT WITH FLASHER**

A vapor-proof light fixture with 50-watt flashing lamp for outdoor pole mounting shall be provided. The light shall flash during alarm conditions. The fixture shall be complete with a red globe and guard.

### **120V ALARM BELL**

A vibratone-type bell mounted on a weather-tight box suitable for pole mounting shall be provided.

### **120V ALARM HORN**

A vibratone-type horn mounted on a weather-tight box suitable for pole mounting shall be provided.

### **12V TRICKLE CHARGER**

Storage batteries and charger shall be supplied to furnish power for operating alarm annunciators in cases of power failure. The storage batteries (two 3-cell, 6-volt) shall be maintenance-free lead-calcium battery concealed in high impact, heat-resistant and permanently sealed containers. The battery charger shall be solid-state, capable of restoring battery to full charge within 12 hours after a discharge, not exceeding 1.5 hours. Brownout protection is standard, and will activate the unit when AC line voltage drops below 85 volts.

### **12V ALARM LIGHT**

A vapor-proof light fixture with 50-watt lamp for outdoor pole mounting shall be provided with a red globe and guard.

### **12V ALARM BELL**

A vibratone-type bell mounted on a weather-tight box suitable for pole mounting shall be provided.

### **12V ALARM HORN**

A vibratone-type horn mounted on a weather-tight box suitable for pole mounting shall be provided.

### **PANEL MOUNTED AUTOMATIC RESET ALARM SILENCE SWITCH**

A momentary contact alarm silencing switch mounted on the control panel shall be provided. The alarm shall automatically be reset when the alarm condition is removed.

# ENGINEERING DATA



Smith &  
Loveless, Inc.®

14040 West Santa Fe Trail Drive  
Lenexa, Kansas 66215-1284

2-Pump Classic Wet Well  
Mounted Pump Station  
Specification  
July, 2012  
Page 15

## REMOTE MOUNTED AUTOMATIC RESET ALARM SILENCE SWITCH

A momentary contact alarm silencing switch mounted in a weatherproof box suitable for pole mounting shall be provided. The alarm shall automatically be reset when the alarm condition is removed.

## REMOTE ALARM CONTACTS

In addition to the common, powered local alarm connection, individual unpowered contacts shall be provided and wired to a terminal strip for field connection to a remote alarm monitoring system (not included).

## ALARM DIALER INTERFACE (DIALER NOT INCLUDED)

Provisions shall be made within the pump station to facilitate the field installation of an alarm dialer, which is to be furnished and installed by others. The alarm dialer shall be as described elsewhere in these specifications. The factory built pump station shall be provided with a mounting bracket approximately 12 inches by 10-5/8 inches to attach and support the alarm dialer, near the station control panel, beneath the fiberglass enclosure. In addition, openings for conduit connections shall be provided in the bottom of the station control panel and through the side of the station base, to facilitate wiring of the alarm dialer input, output and power connections. In addition to the powered common local alarm contact, the station control panel shall have terminal strip connections for fault-opening alarm contacts to provide discrete alarm input signals to the dialer and shall also include terminal strip connections for a 1/60/120 volt power source, on a separate 15-amp circuit, to power the dialer. Wiring of the dialer shall be done by others during installation of the station in the field.

## BASE1-BASE2-AUTO ALTERNATE SELECTOR SWITCH

A 3-position selector switch shall be mounted on the face of the control panel to allow selection of either pump as the lead pump, or to allow for automatic alternation.

## SURGE PROTECTIVE DEVICE

A surge protective device for lightning and surge protection with an internal automatic discharge circuit and rated for three-phase service shall be provided.

## TIME DELAY

The pump control system shall provide for a time delay to prevent simultaneously starting the pump motors after power failure.

## SEQUENTIAL ALTERNATION

In lieu of the timed alternation system, provisions shall be made to alternate the pumps at the completion of each pumping cycle.

## GENERATOR INTERLOCK

Provisions shall be made in the control circuit of the lift station to facilitate locking out the standby pump when the emergency generator set is powering the station. An interlock consisting of a normally closed auxiliary contact shall be supplied with the emergency generator controls by the generator manufacturer. This normally closed contact shall be wired to the terminal blocks provided in the lift station control panel by the lift station manufacturer. The interconnecting wiring shall be supplied and connected by the installing contractor.

## ADD-A-PHASE INTERFACE

Terminals shall be provided in the lift station control panel to facilitate connection to an external Add-A-Phase phase converter unit.

## ROTO PHASE INTERFACE

Terminals and a time delay to prevent simultaneously starting the pump motors after power failure shall be provided in the lift station control panel to facilitate connection to an external Roto Phase phase converter unit.

# ENGINEERING DATA



Smith &  
Loveless, Inc.®

14040 West Santa Fe Trail Drive  
Lenexa, Kansas 66215-1284

2-Pump Classic Wet Well  
Mounted Pump Station  
Specification  
July, 2012  
Page 16

## **INTRINSICALLY SAFE CONTROL**

Intrinsically safe relays to provide low current isolated switching for the float switches shall be provided.

## **MAIN CIRCUIT BREAKER**

A main circuit breaker shall be installed in the control panel to provide over-current protection for the station, and shall be capable of being used to disconnect the three-phase power to the pump station. The breaker shall be operable without opening the panel, and shall be interlocked with the panel door. It shall be capable of being padlocked in the "Off" position.

## **SOLID-STATE REDUCED VOLTAGE STARTERS**

UL listed, solid-state reduced voltage starters shall be supplied. The starters shall be capable of a soft start and soft stop. The starters shall have built in overload protection as well as built in bypass contactors. One set of form C auxiliary contacts shall be supplied on the starter. The starters shall be powered by 24V DC and shall have a built-in Digital Signal Processor utilizing a low impedance run circuit. The starters shall be easily programmable by using a standard screwdriver.

## **PHASE MONITOR**

A relay with double pole, double throw contacts shall be provided to monitor and protect against phase loss (single-phasing), under voltage (brownouts) and phase reversal (improper sequence). It shall automatically reset when three-phase service returns to normal.

## **SINGLE-PHASE POWER MONITOR**

A relay shall be provided to monitor the 120-Volt single-phase control power supply and initiate an alarm on loss of power. It shall automatically reset when the single-phase service returns to normal.

## **PUMP PRIME FAILURE**

A time delay relay shall be connected to each vacuum pump. Contacts shall be provided to automatically shut down the operating vacuum pump, allow starting of the next pump in the operating sequence and signal an alarm on excessive vacuum pump operating time. Contacts shall be provided for transmitting an alarm signal.

## **OPERATOR ASSIST ALARM**

The station control panel shall be provided with a maintained contact, manually operated, red mushroom-head Operator Assist Alarm Button in an easily accessible position on the control panel to signal emergency operator assistance is required. It also may be used to provide means for testing the alarm system.

## **UNAUTHORIZED ENTRY ALARM**

A timer circuit shall be provided in the control panel to signal unauthorized entry into the pump station. The timer shall be activated whenever the fiberglass cover is opened. A key operated switch shall be provided on the station control panel to provide authorized personnel a means to deactivate the alarm before the timer completes its cycle.

## **NEMA STARTERS**

NEMA rated magnetic across-the-line starters with overload protection for each phase shall be provided for each pump motor to give positive protection against phase unbalance, thermal overload, phase loss and ground fault.

## **AUXILIARY STATION HEATER**

A 1300/1500 watt, dual range, electric heater with automatic circulating fan, thermostat control and an On/Off switch is to be provided. The heater is to be operated by connection to the station convenience receptacle.

## **INSULATED HOOD**

The fiberglass cover shall have a minimum of 1" thick urethane insulation, protected by fiberglass, with an "R" value of 7 or more.



# ENGINEERING DATA



Smith &  
Loveless, Inc.®

14040 West Santa Fe Trail Drive  
Lenexa, Kansas 66215-1284

2-Pump Classic Wet Well  
Mounted Pump Station  
Specification  
July, 2012  
Page 17

## CERTIFIED CURVES

Factory-certified performance test curves shall be provided for the pumps, tested after installation in the station, to simulate actual operating conditions. Copies of these curves, showing head, flow, BHP, efficiency and the backup data, shall be provided with the station. Typical data or curves from a similar pump are not acceptable. Data and curves must be for the actual pumps provided, and while mounted in the station.

## WET WELL BLOWER

A ventilating blower capable of delivering 100 CFM shall be provided for ventilation of the wet well. The wet well blower shall be enclosed in a NEMA 3R rain-tight cabinet with a louvered cover and shall be mounted on the station base adjacent to the manway access hatch. A manual switch on the control panel shall operate the blower.

## REMOVE FIBERGLASS ENCLOSURE

The fiberglass enclosure, station ventilating blower and 500-Watt electric heater shall not be provided.

## REMOVE MANWAY ACCESS COVER

The aluminum treadplate manway access cover, stainless steel piano hinge and hardware shall not be provided.

## LIQUID FILLED GAUGES

The compound gauges shall be filled with a viscous fluid to dampen vibration and pulsation effects on the needle reading.

## PROTECTED LIQUID FILLED COMPOUND PRESSURE GAUGES

A four-inch (4") Bourdon tube-type compound vacuum/pressure gauge with 3-1/2" dial, fitted with a brass stop valve and a manual air relief valve shall be provided for each pump. The gauges shall be mounted apart from the pumps, on a bracket attached to the control panel support structure, and connected to the pump discharge taps by flexible tubing to minimize vibration. The range of each gauge shall be selected to place the normal operating discharge pressure reading in the middle one-third of the scale and the gauge shall also be capable of measuring up to 30" HG of vacuum. The dial shall be white with black markings and the gauge itself shall have an accuracy of 1% of scale. The gauge shall be American made, with a Zytel Nylon case with 1/2" blow-out plug, stainless steel bezel, acrylic lens and phosphorus bronze tube with brass socket. Each compound gauge shall be filled with a viscous fluid to dampen vibration and pulsation effects on the needle reading. Temperature compensation shall be provided by an internal compensating diaphragm. Gauges shall be protected from the service fluid by a Buna-N elastomer "boot" diaphragm within the stem, and the Bourdon tube and the space between the Bourdon tube and the internal isolating diaphragm shall be filled with low temperature instrument oil, completely isolating the gauge components from the fluid being measured.

## EMERGENCY PUMPING CONNECTION

The common discharge pipe of the pump station shall be fitted with a branch with a plug valve and male quick-connect fitting with cap, as shown on the drawings, to facilitate connection of a portable emergency pump to the force main to bypass the pump station. The emergency pumping connection shall be housed within the fiberglass cover.

## TOOLKIT

A metal toolbox complete with the following tools shall be provided. This complement of tools shall include all tools necessary to replace the pump mechanical seal.

9/16" x 1/2" Box End Wrench  
3/4" x 5/8" Open End Wrench  
15/16" x 1" Open End Wrench  
1-1/8" Socket  
8" T-Handle 11" x 1/2" Drive  
1/2" x 5-1/2" Drive Extension  
6" Pipe Wrench



# ENGINEERING DATA



Smith &  
Loveless, Inc.®

14040 West Santa Fe Trail Drive  
Lenexa, Kansas 66215-1284

2-Pump Classic Wet Well  
Mounted Pump Station  
Specification  
July, 2012  
Page 18

#3 Rawhide Mallet  
Ratchet-Type Hoist  
Motor Lifting Bar  
Lint-Free Cloth  
Multi-Purpose Grease

## **ADDITIONAL SPARE MECHANICAL SEALS**

In addition to the one standard spare mechanical seal, \_\_\_\_ additional spare mechanical seal(s) shall be provided. The spare seal(s) shall be packed in a suitable container and shall include complete installation instructions.

## **WET WELL FALL PROTECTION BARRIER**

A fall protection safety barrier to prevent personnel, tools or equipment from falling through the manway opening and into the wet well when the manway cover is in the raised position, shall be provided by the station manufacturer for field installation in the wet well by the installing contractor. The fall protection barrier shall be constructed of aluminum bar grating and shall cover the area beneath the manway cover. Stainless steel hinges and a lifting handle shall be provided for convenience. When fully open, the fall protection safety barrier can be latched open for safe entering and exiting of the wet well. All components shall be constructed of stainless steel except for the aluminum grating. The barrier shall be capable of holding a 400-pound concentrated load, when in the Closed position. The wet well fall protection barrier kit shall include the aluminum grating barrier, 304 SST hinges, 304 SST mounting brackets, 304 SST hardware, the required number of 1/2" diameter 304 SST wedge anchors for the specific wet well kit size and a complete set of instructions for installation of the fall protection barrier in a foot diameter wet well.

## **TEST UNIT WITH BATTERY FOR MULTI-SENSOR CHECK VALVE SWITCH [FOR USE WITH RELAY LOGIC CONTROLS. NOT REQUIRED WITH PROTRONIX® II OR PumpLogix™ CONTROLLERS]**

To test or set the multi-sensor check valve switches using the built-in LED light with Relay Logic control systems, a separate hand held battery pack with connecting cord and plug shall be provided. This is to enable the operator to accurately set the trip point of the switch manually, by means of the built-in test light on the multi-sensor.

# ENGINEERING DATA



Smith &  
Loveless, Inc.®

14040 West Santa Fe Trail Drive  
Lenexa, Kansas 66215-1284

Standard 2-Pump Wet Well  
Mounted Pump Station  
Electrical Service Data  
July, 2012  
Page 1

## ELECTRICAL SERVICE DATA STANDARD 2-PUMP WET WELL MOUNTED PUMP STATION

MAIN PUMP MOTOR SIZE	TOTAL STATION FULL LOAD AMPS			
	RATED HP EACH	208 VOLT	230 VOLT	460 VOLT
1		17.6	15.3	7.6
1-1/2		21.8	18.9	9.5
2		25.9	22.5	11.3
3		33.1	28.8	14.5
5		47.7	41.4	20.7
7-1/2		65.3	56.7	28.4
10		80.8	70.2	35.1
15		117.0	101.7	50.9
20		148.1	128.7	64.4
25		190.44	160.2	80.1
30		215.3	187.2	93.6
40		---	---	120.6
50		---	---	150.0

ASSUMING 3 KVA LOAD FOR CONTROLS

**NOTE:** Refer to applicable station drawing for size of electrical conduit connection.

# ENGINEERING DATA



Smith & Loveless, Inc.®

14040 West Santa Fe Trail Drive  
Lenexa, Kansas 66215-1284

2-Pump Classic Wet Well Mounted Pump Station  
Outline Drawing 87C411  
4B2C Pump – 4" Piping  
July, 2012

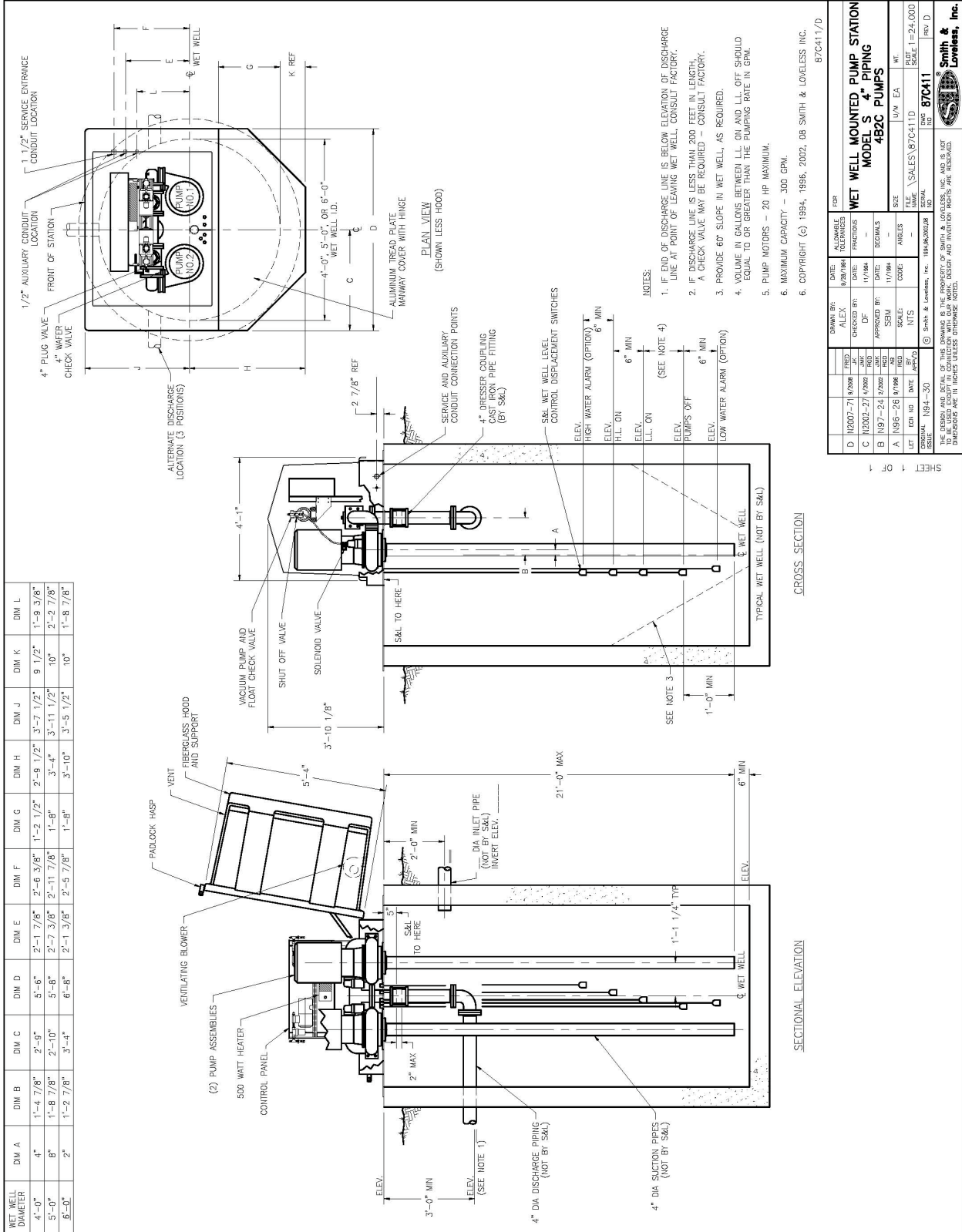

- NOTES:
1. IF END OF DISCHARGE LINE IS BELOW ELEVATION OF DISCHARGE LINE AT POINT OF LEAVING WET WELL, CONSULT FACTORY.
  2. IF DISCHARGE LINE IS LESS THAN 200 FEET IN LENGTH, A CHECK VALVE MAY BE REQUIRED - CONSULT FACTORY.
  3. PROVIDE 60° SLOPE IN WET WELL, AS REQUIRED.
  4. VOLUME IN GALLONS BETWEEN L.L. ON AND L.L. OFF SHOULD EQUAL TO OR GREATER THAN THE PUMPING RATE IN GPM.
  5. PUMP MOTORS - 20 HP MAXIMUM.
  6. MAXIMUM CAPACITY - 300 GPM.
  7. COPYRIGHT (c) 1994, 1995, 2002, 08 SMITH & LOVELESS INC.

DATE	BY	CHKD	APP'D	DESCRIPTION
1/2007-7/1/2008	ALEX	1/2008	1/2008	FOR TOLERANCES
1/2007-7/1/2008	ALEX	1/2008	1/2008	FOR DIMENSIONS
1/2007-7/1/2008	ALEX	1/2008	1/2008	FOR FINISHES
1/2007-7/1/2008	ALEX	1/2008	1/2008	FOR MATERIALS
1/2007-7/1/2008	ALEX	1/2008	1/2008	FOR METHODS
1/2007-7/1/2008	ALEX	1/2008	1/2008	FOR EQUIPMENT
1/2007-7/1/2008	ALEX	1/2008	1/2008	FOR TESTING
1/2007-7/1/2008	ALEX	1/2008	1/2008	FOR PROTECTION
1/2007-7/1/2008	ALEX	1/2008	1/2008	FOR MAINTENANCE
1/2007-7/1/2008	ALEX	1/2008	1/2008	FOR RECORDS

WET WELL MOUNTED PUMP STATION  
MODEL S 4" PIPING  
4B2C PUMPS

SCALE: 1"=24.000  
DATE: 8/7/2011  
REV: 0

SMITH & LOVELESS, INC.



# ENGINEERING DATA



Smith &  
Loveless, Inc.®

14040 West Santa Fe Trail Drive  
Lenexa, Kansas 66215-1284

2-Pump Classic Wet Well  
Mounted Pump Station  
4B2B / 4B2X / 4B2D / 4C2B /  
4C2D / 4C2X - 4" Piping  
Model S  
Drawing 87C405  
July, 2012

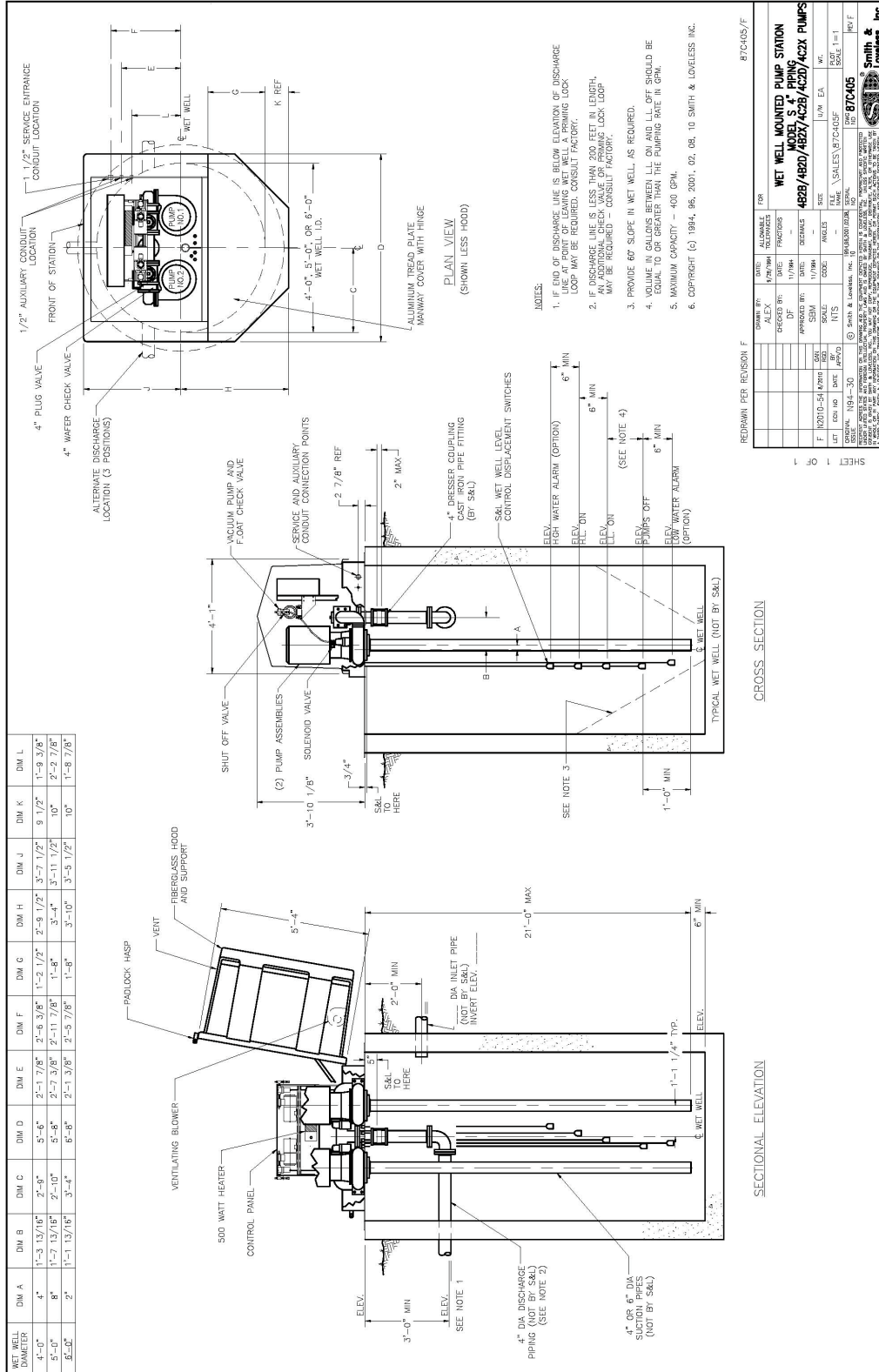

# ENGINEERING DATA



Smith & Loveless, Inc.®

14040 West Santa Fe Trail Drive  
Lenexa, Kansas 66215-1284

2-Pump Classic Wet Well  
Mounted Pump Station  
4B2B / 4B2X / 4B2D / 4C2B /  
4C2D / 4C2X – 6" Piping  
Model S  
Drawing 87C406  
July, 2012

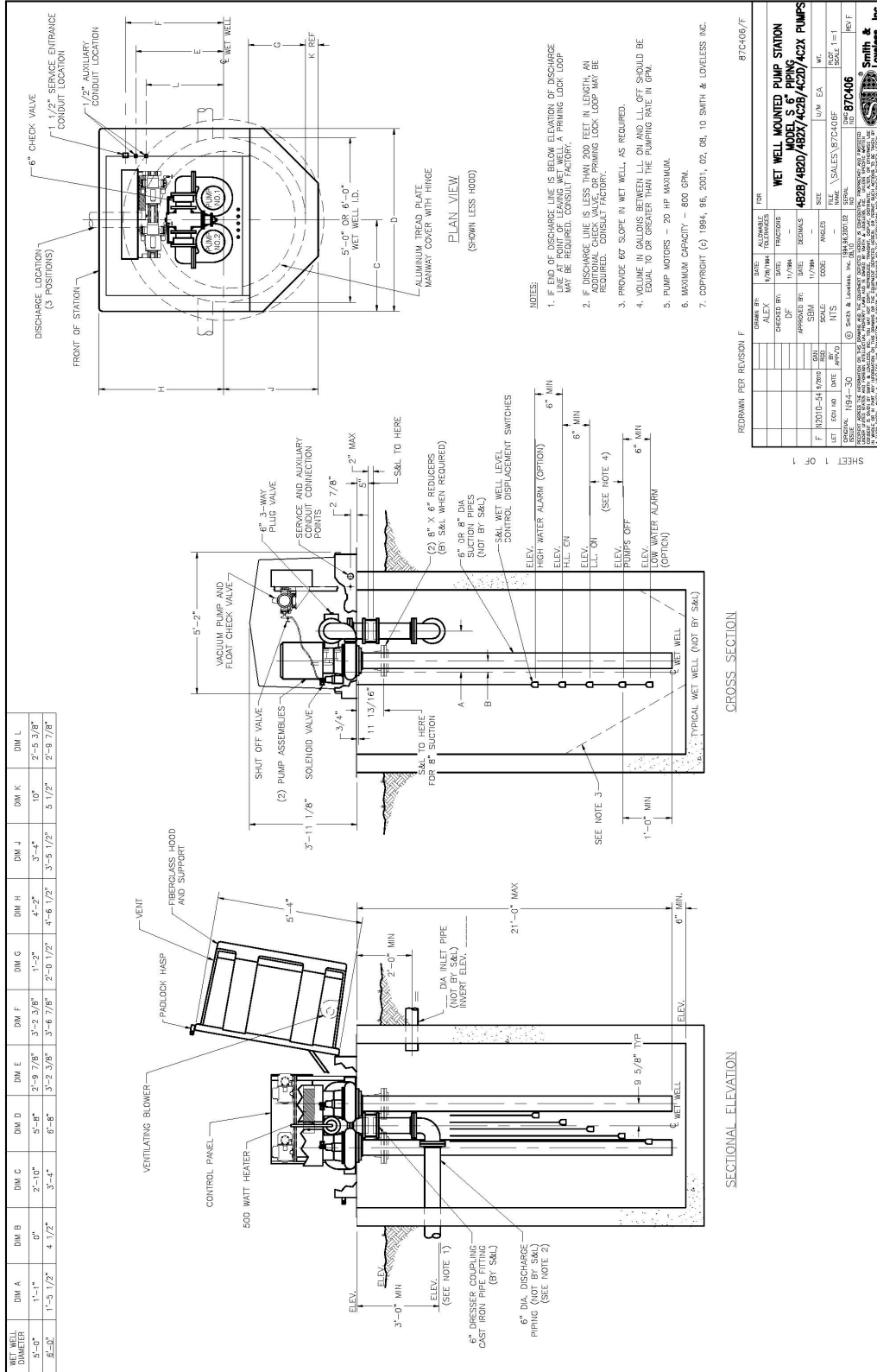



# ENGINEERING DATA



Smith & Loveless, Inc.®

14040 West Santa Fe Trail Drive  
Lenexa, Kansas 66215-1284

2-Pump Classic Wet Well  
Mounted Pump Station  
Outline Drawing 87C407  
4B3B / 4C3B / 4D3B Pumps  
4" Piping – Model S  
July, 2012

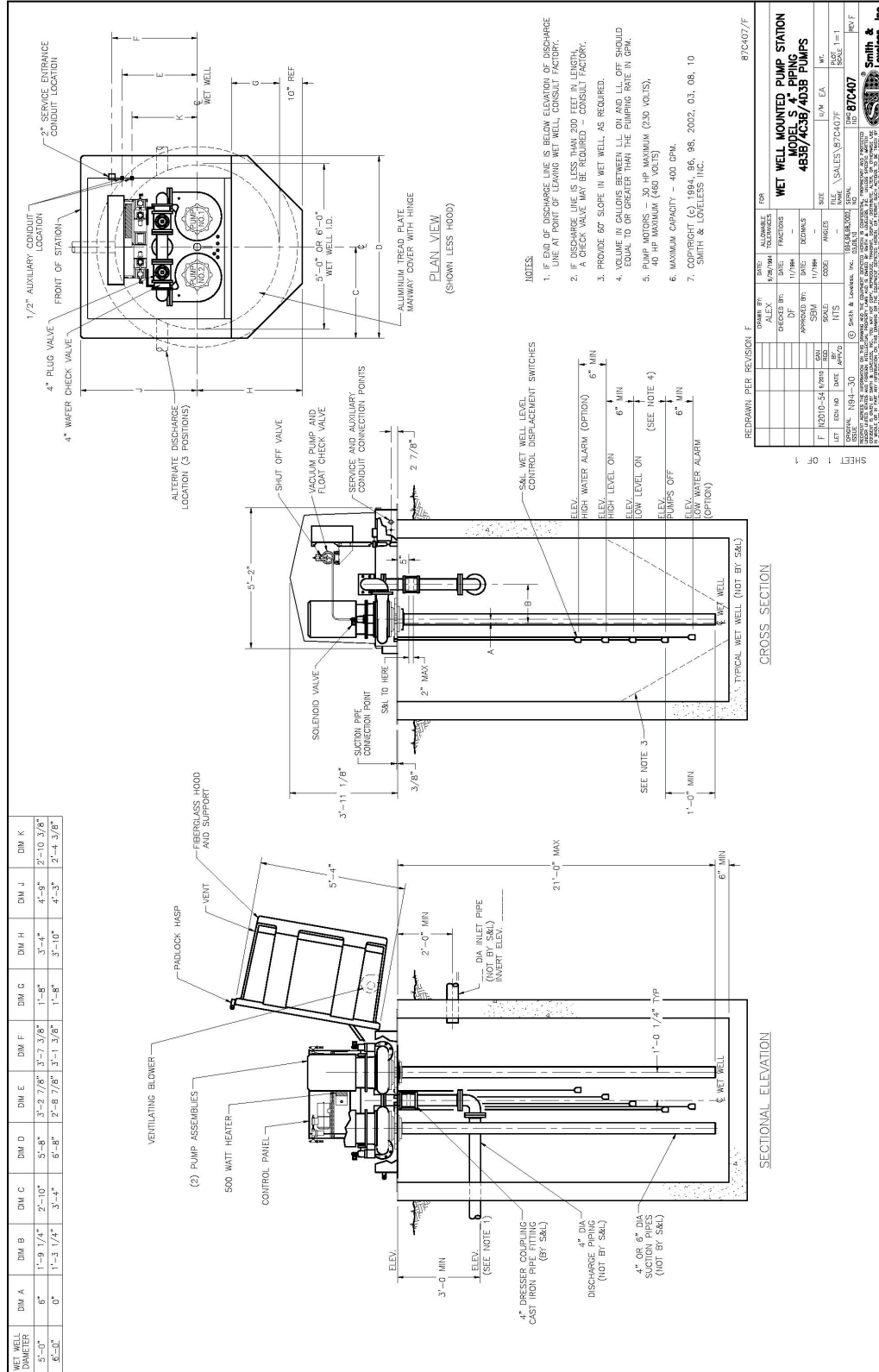

# ENGINEERING DATA



Smith & Loveless, Inc.®

14040 West Santa Fe Trail Drive  
Lenexa, Kansas 66215-1284

2-Pump Classic Wet Well  
Mounted Pump Station  
Outline Drawing 87C408  
4B3B / 4C3B / 4D3B Pumps  
6" Piping – Model S  
July, 2012

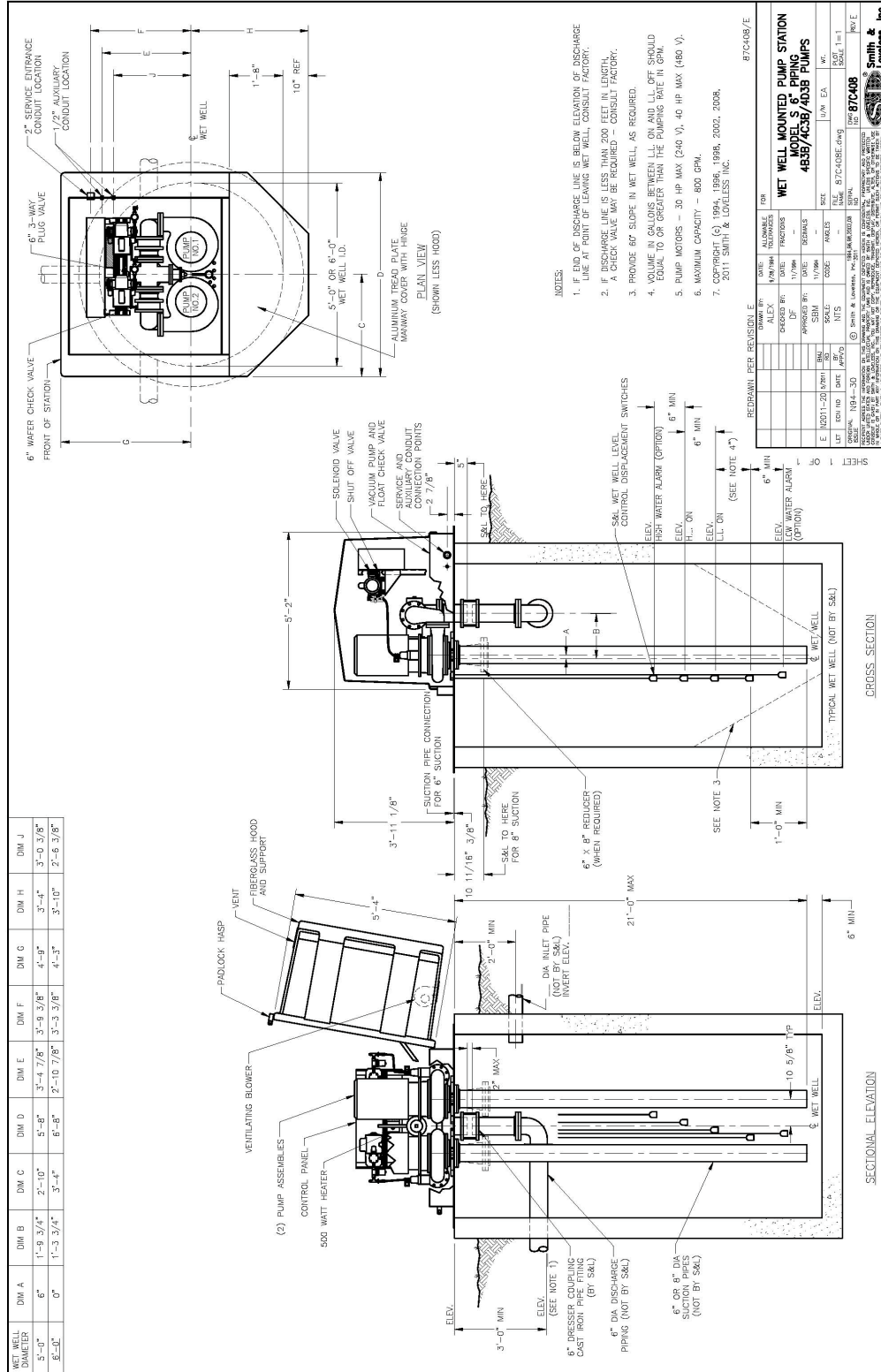



# ENGINEERING DATA



Smith & Loveless, Inc.®

14040 West Santa Fe Trail Drive  
Lenexa, Kansas 66215-1284

2-Pump Classic Wet Well  
Mounted Pump Station  
Outline Drawing 87B335  
4D4B Pumps  
4" Piping - 6" x 4" x 4"  
July, 2012

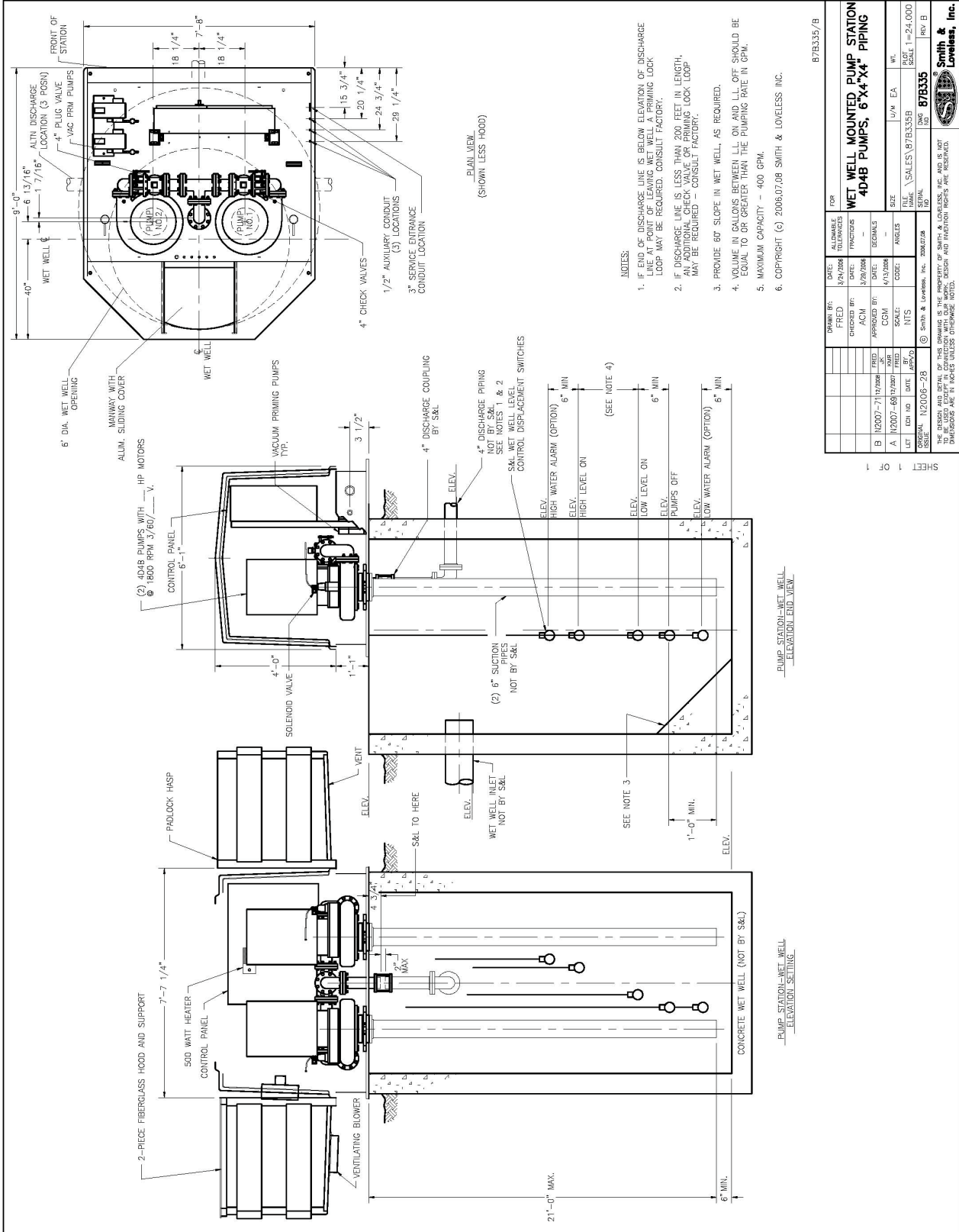

DATE	BY	DESCRIPTION
1/24/2008	FRED	ISSUED FOR PERMITS
2/26/2008	ACM	FOR COMMENTS
4/15/2008	COH	FOR COMMENTS
4/15/2008	INTS	FOR COMMENTS
4/15/2008	INTS	FOR COMMENTS

DATE	BY	DESCRIPTION
1/24/2008	FRED	ISSUED FOR PERMITS
2/26/2008	ACM	FOR COMMENTS
4/15/2008	COH	FOR COMMENTS
4/15/2008	INTS	FOR COMMENTS
4/15/2008	INTS	FOR COMMENTS

DATE	BY	DESCRIPTION
1/24/2008	FRED	ISSUED FOR PERMITS
2/26/2008	ACM	FOR COMMENTS
4/15/2008	COH	FOR COMMENTS
4/15/2008	INTS	FOR COMMENTS
4/15/2008	INTS	FOR COMMENTS

DATE	BY	DESCRIPTION
1/24/2008	FRED	ISSUED FOR PERMITS
2/26/2008	ACM	FOR COMMENTS
4/15/2008	COH	FOR COMMENTS
4/15/2008	INTS	FOR COMMENTS
4/15/2008	INTS	FOR COMMENTS

DATE	BY	DESCRIPTION
1/24/2008	FRED	ISSUED FOR PERMITS
2/26/2008	ACM	FOR COMMENTS
4/15/2008	COH	FOR COMMENTS
4/15/2008	INTS	FOR COMMENTS
4/15/2008	INTS	FOR COMMENTS

DATE	BY	DESCRIPTION
1/24/2008	FRED	ISSUED FOR PERMITS
2/26/2008	ACM	FOR COMMENTS
4/15/2008	COH	FOR COMMENTS
4/15/2008	INTS	FOR COMMENTS
4/15/2008	INTS	FOR COMMENTS

DATE	BY	DESCRIPTION
1/24/2008	FRED	ISSUED FOR PERMITS
2/26/2008	ACM	FOR COMMENTS
4/15/2008	COH	FOR COMMENTS
4/15/2008	INTS	FOR COMMENTS
4/15/2008	INTS	FOR COMMENTS

DATE	BY	DESCRIPTION
1/24/2008	FRED	ISSUED FOR PERMITS
2/26/2008	ACM	FOR COMMENTS
4/15/2008	COH	FOR COMMENTS
4/15/2008	INTS	FOR COMMENTS
4/15/2008	INTS	FOR COMMENTS

DATE	BY	DESCRIPTION
1/24/2008	FRED	ISSUED FOR PERMITS
2/26/2008	ACM	FOR COMMENTS
4/15/2008	COH	FOR COMMENTS
4/15/2008	INTS	FOR COMMENTS
4/15/2008	INTS	FOR COMMENTS

DATE	BY	DESCRIPTION
1/24/2008	FRED	ISSUED FOR PERMITS
2/26/2008	ACM	FOR COMMENTS
4/15/2008	COH	FOR COMMENTS
4/15/2008	INTS	FOR COMMENTS
4/15/2008	INTS	FOR COMMENTS

DATE	BY	DESCRIPTION
1/24/2008	FRED	ISSUED FOR PERMITS
2/26/2008	ACM	FOR COMMENTS
4/15/2008	COH	FOR COMMENTS
4/15/2008	INTS	FOR COMMENTS
4/15/2008	INTS	FOR COMMENTS

DATE	BY	DESCRIPTION
1/24/2008	FRED	ISSUED FOR PERMITS
2/26/2008	ACM	FOR COMMENTS
4/15/2008	COH	FOR COMMENTS
4/15/2008	INTS	FOR COMMENTS
4/15/2008	INTS	FOR COMMENTS

DATE	BY	DESCRIPTION
1/24/2008	FRED	ISSUED FOR PERMITS
2/26/2008	ACM	FOR COMMENTS
4/15/2008	COH	FOR COMMENTS
4/15/2008	INTS	FOR COMMENTS
4/15/2008	INTS	FOR COMMENTS

# ENGINEERING DATA



Smith & Loveless, Inc.®

14040 West Santa Fe Trail Drive  
Lenexa, Kansas 66215-1284

2-Pump Classic Wet Well Mounted Pump Station  
Outline Drawing 87B336  
4D4B Pumps  
6" Piping – 6" x 6" x 6"  
July, 2012

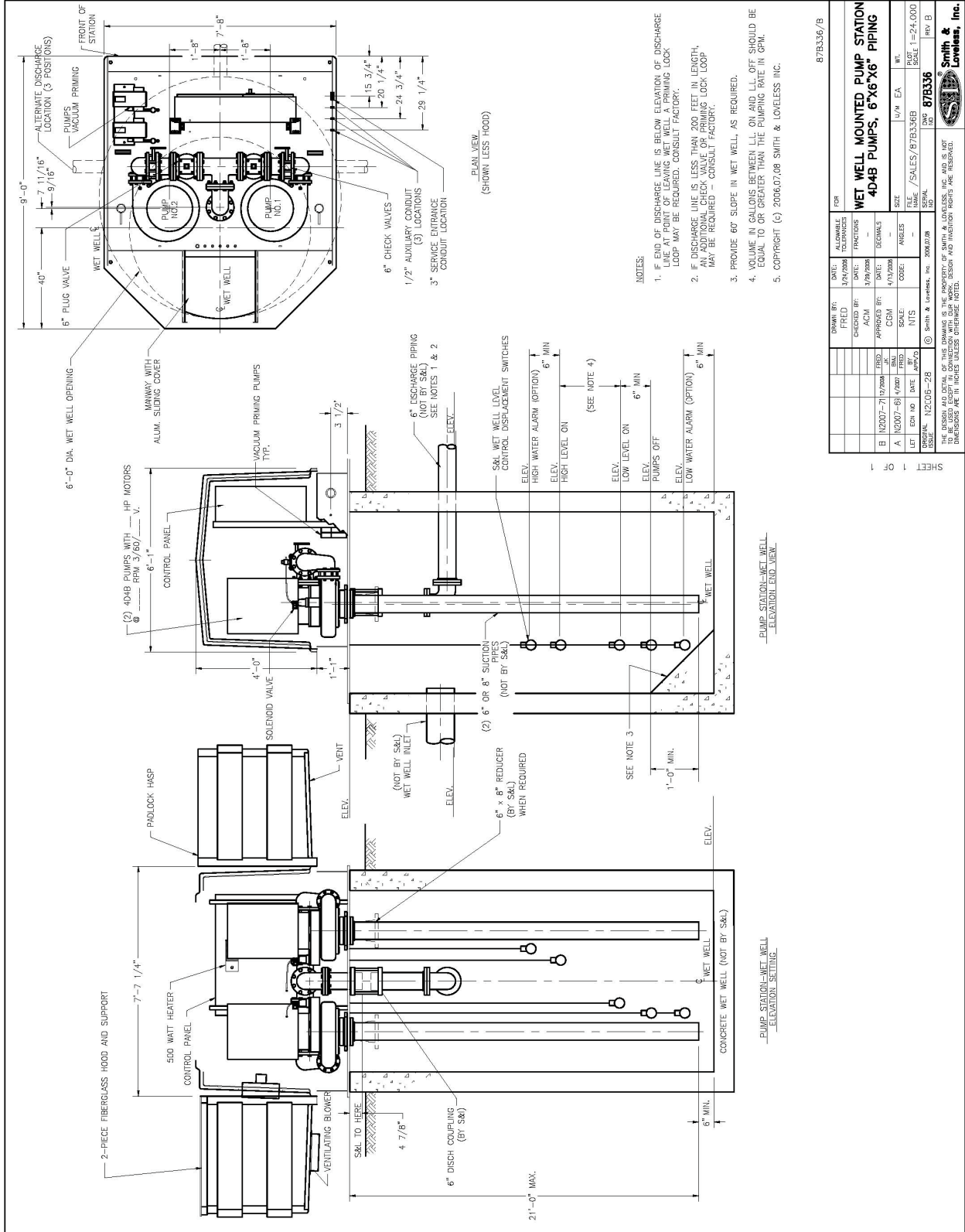

DATE	DESCRIPTION	BY	CHKD	APP'D
1/24/2008	ALLOWABLE TOLERANCES			
3/9/2008	FUNCTIONS			
4/12/2008	REVISIONS			
4/12/2008	DESIGN			
4/12/2008	CONSTRUCTION			
4/12/2008	OPERATION			
4/12/2008	MAINTENANCE			
4/12/2008	SALES			
4/12/2008	ISSUE			

DATE	DESCRIPTION	BY	CHKD	APP'D
1/24/2008	ALLOWABLE TOLERANCES			
3/9/2008	FUNCTIONS			
4/12/2008	REVISIONS			
4/12/2008	DESIGN			
4/12/2008	CONSTRUCTION			
4/12/2008	OPERATION			
4/12/2008	MAINTENANCE			
4/12/2008	SALES			
4/12/2008	ISSUE			

DATE	DESCRIPTION	BY	CHKD	APP'D
1/24/2008	ALLOWABLE TOLERANCES			
3/9/2008	FUNCTIONS			
4/12/2008	REVISIONS			
4/12/2008	DESIGN			
4/12/2008	CONSTRUCTION			
4/12/2008	OPERATION			
4/12/2008	MAINTENANCE			
4/12/2008	SALES			
4/12/2008	ISSUE			

DATE	DESCRIPTION	BY	CHKD	APP'D
1/24/2008	ALLOWABLE TOLERANCES			
3/9/2008	FUNCTIONS			
4/12/2008	REVISIONS			
4/12/2008	DESIGN			
4/12/2008	CONSTRUCTION			
4/12/2008	OPERATION			
4/12/2008	MAINTENANCE			
4/12/2008	SALES			
4/12/2008	ISSUE			

DATE	DESCRIPTION	BY	CHKD	APP'D
1/24/2008	ALLOWABLE TOLERANCES			
3/9/2008	FUNCTIONS			
4/12/2008	REVISIONS			
4/12/2008	DESIGN			
4/12/2008	CONSTRUCTION			
4/12/2008	OPERATION			
4/12/2008	MAINTENANCE			
4/12/2008	SALES			
4/12/2008	ISSUE			

# ENGINEERING DATA



Smith &  
Loveless, Inc.®

14040 West Santa Fe Trail Drive  
Lenexa, Kansas 66215-1284

2-Pump Classic Wet Well  
Mounted Pump Station  
Outline Drawing 87C409  
6B3\_ / 6C3\_ / 6D3\_ Pumps  
6" Piping – Model S  
July, 2012

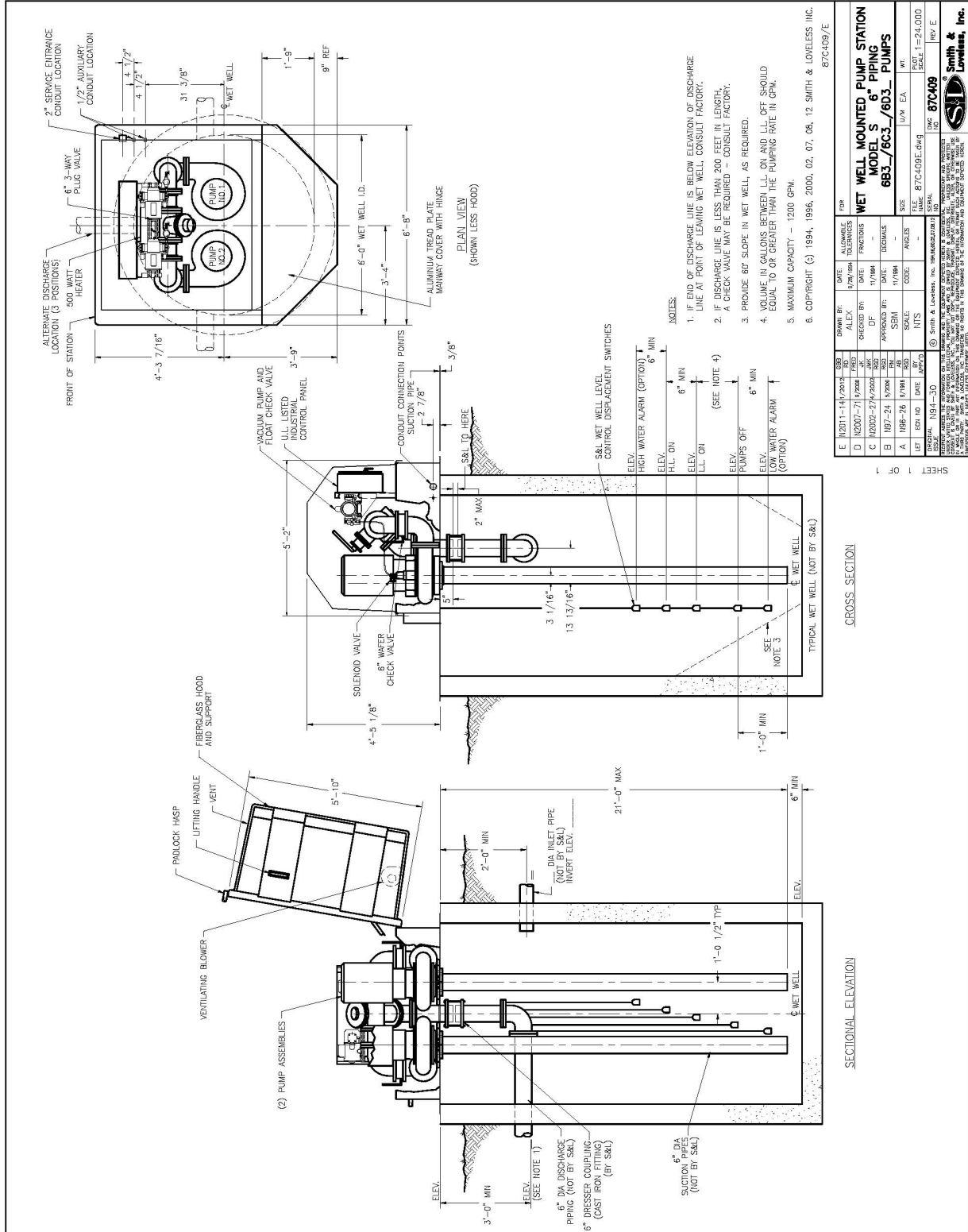

REV	DATE	DESCRIPTION
E	11/01/11	141/2011
D	11/02/11	11/2011
C	11/02/11	11/2011
B	11/02/11	11/2011
A	11/02/11	11/2011

REV	DATE	DESCRIPTION
1	07/11/12	7/11/12
2	07/11/12	7/11/12
3	07/11/12	7/11/12
4	07/11/12	7/11/12
5	07/11/12	7/11/12
6	07/11/12	7/11/12
7	07/11/12	7/11/12
8	07/11/12	7/11/12
9	07/11/12	7/11/12
10	07/11/12	7/11/12
11	07/11/12	7/11/12
12	07/11/12	7/11/12
13	07/11/12	7/11/12
14	07/11/12	7/11/12
15	07/11/12	7/11/12
16	07/11/12	7/11/12
17	07/11/12	7/11/12
18	07/11/12	7/11/12
19	07/11/12	7/11/12
20	07/11/12	7/11/12
21	07/11/12	7/11/12
22	07/11/12	7/11/12
23	07/11/12	7/11/12
24	07/11/12	7/11/12
25	07/11/12	7/11/12
26	07/11/12	7/11/12
27	07/11/12	7/11/12
28	07/11/12	7/11/12
29	07/11/12	7/11/12
30	07/11/12	7/11/12
31	07/11/12	7/11/12
32	07/11/12	7/11/12
33	07/11/12	7/11/12
34	07/11/12	7/11/12
35	07/11/12	7/11/12
36	07/11/12	7/11/12
37	07/11/12	7/11/12
38	07/11/12	7/11/12
39	07/11/12	7/11/12
40	07/11/12	7/11/12
41	07/11/12	7/11/12
42	07/11/12	7/11/12
43	07/11/12	7/11/12
44	07/11/12	7/11/12
45	07/11/12	7/11/12
46	07/11/12	7/11/12
47	07/11/12	7/11/12
48	07/11/12	7/11/12
49	07/11/12	7/11/12
50	07/11/12	7/11/12



# ENGINEERING DATA



Smith & Loveless, Inc.®

14040 West Santa Fe Trail Drive  
Lenexa, Kansas 66215-1284

2-Pump Classic Wet Well Mounted Pump Station  
Wiring Diagram 87B515  
July, 2012

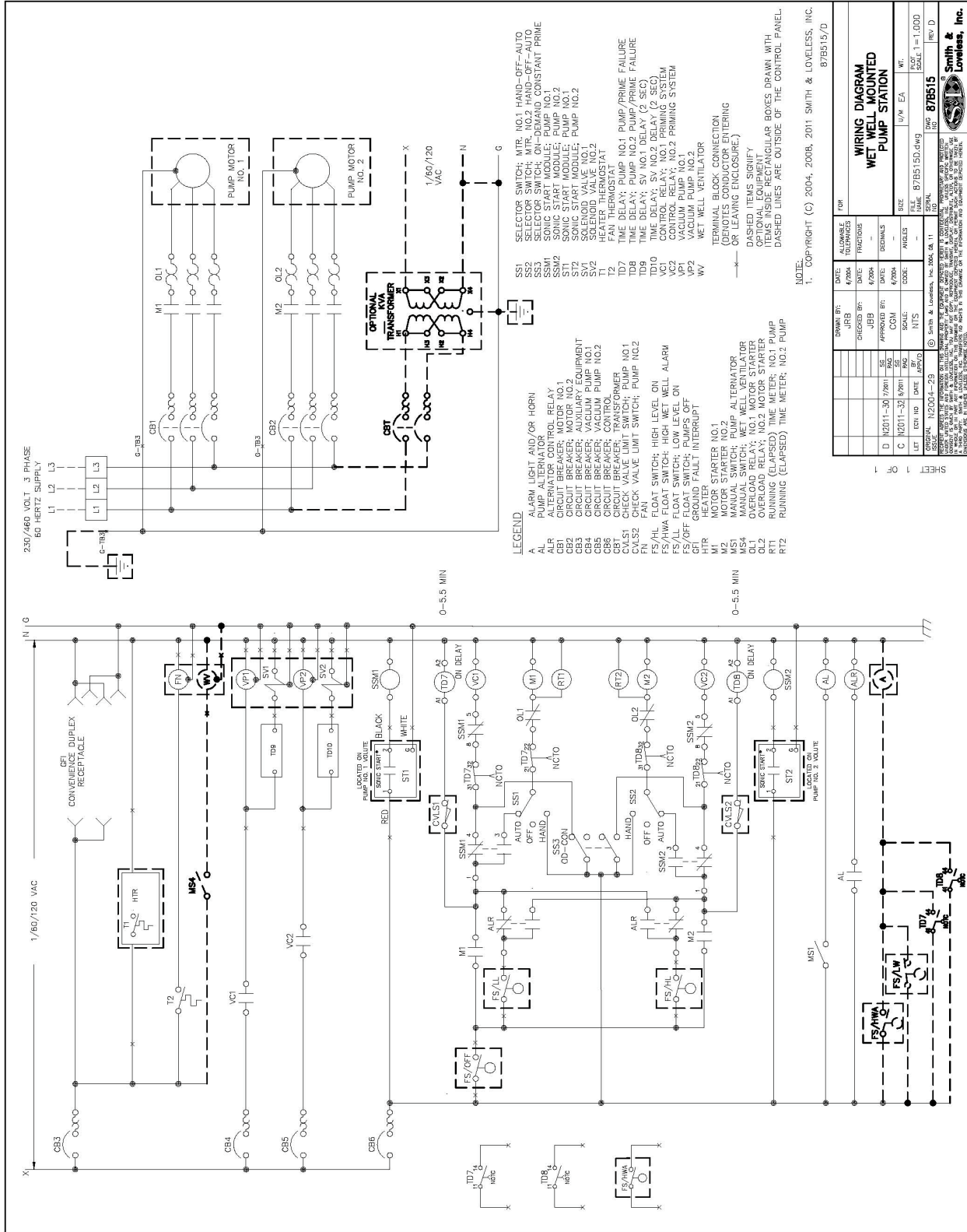











# ENGINEERING DATA



Smith &  
Loveless, Inc.®

14040 West Santa Fe Trail Drive  
Lenexa, Kansas 66215-1284

2-Pump Classic Wet Well  
Mounted Pump Station  
Outline Drawing 87C375  
8C4D / 8D4D Pumps – 10" Piping  
12" Suction, 10" Discharge  
July, 2012

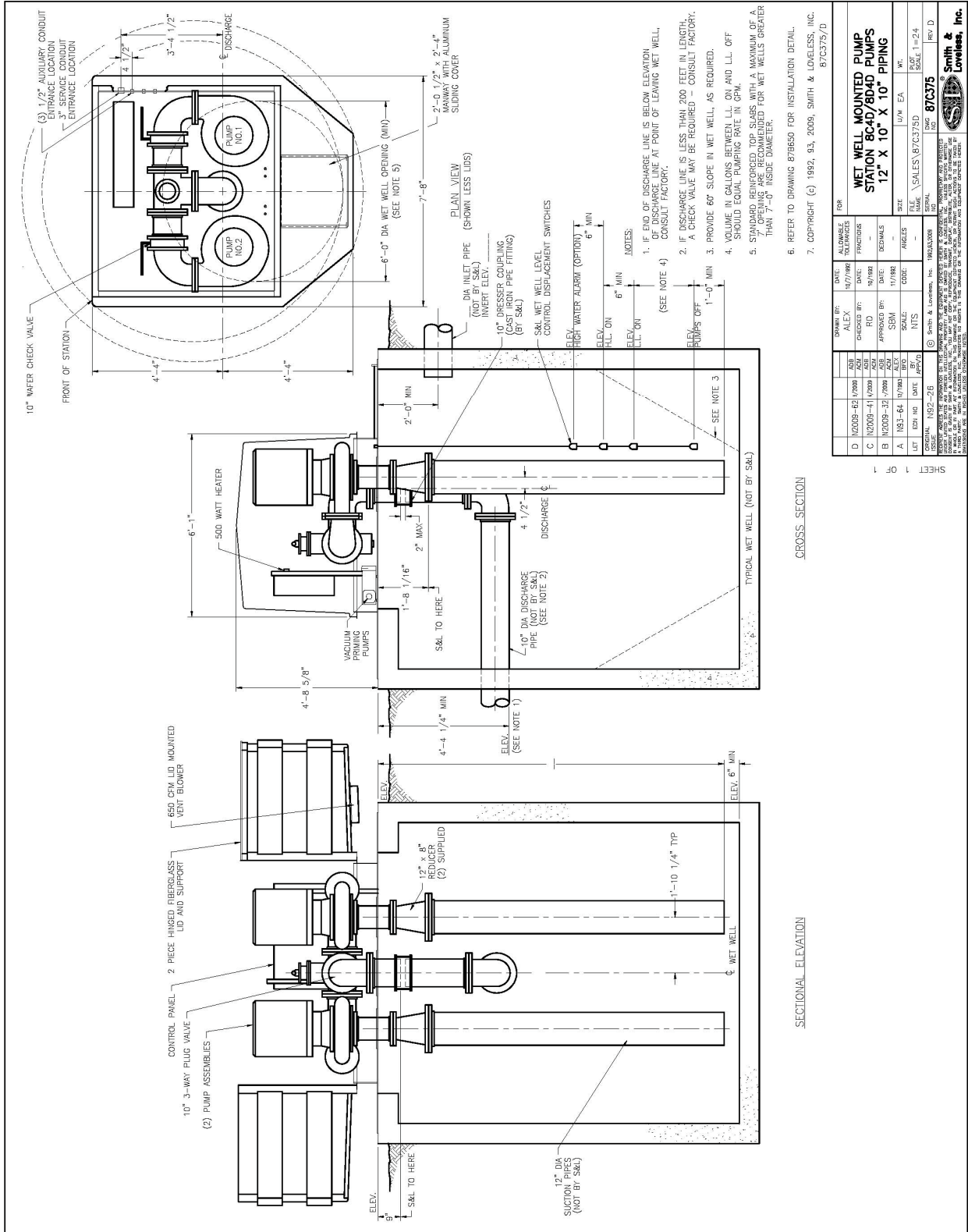



# ENGINEERING DATA



Smith &  
Loveless, Inc.®

14040 West Santa Fe Trail Drive  
Lenexa, Kansas 66215-1284

Large Wet Well Installation  
8C4D / 8D4D Pumps  
Drawing 87C347  
July, 2012

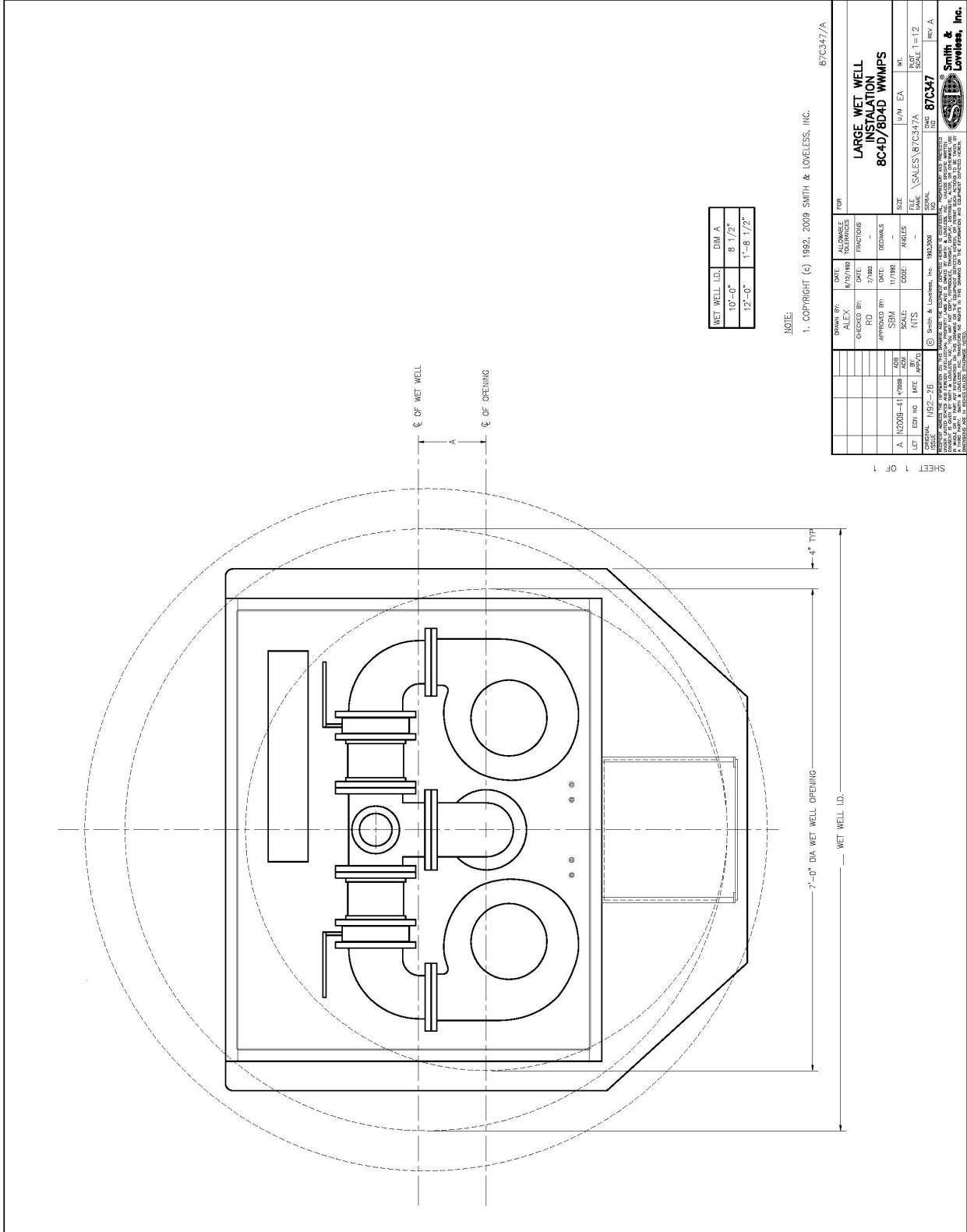

NOTE:  
1. COPYRIGHT (c) 1992, 2009 SMITH & LOVELESS, INC.

DATE	BY	DESCRIPTION	REV. A
10/2/1989	ALEX	ALLOWABLE DIMENSIONS	1
11/7/1989	SM	PROVISIONS	2
11/7/1989	SM	DETAILS	3
11/7/1989	SM	DETAILS	4
11/7/1989	SM	DETAILS	5
11/7/1989	SM	DETAILS	6
11/7/1989	SM	DETAILS	7
11/7/1989	SM	DETAILS	8
11/7/1989	SM	DETAILS	9
11/7/1989	SM	DETAILS	10
11/7/1989	SM	DETAILS	11
11/7/1989	SM	DETAILS	12

SERIAL NO. 87C347  
 DATE 8/7/12  
 DRAWN BY VSALES  
 CHECKED BY VSALES  
 APPROVED BY VSALES  
 SCALE 1" = 12"  
 SHEET 1 OF 1

# ENGINEERING DATA



Smith & Loveless, Inc.®

14040 West Santa Fe Trail Drive  
Lenexa, Kansas 66215-1284

2-Pump Classic Wet Well Mounted Pump Station  
Outline Drawing 87B648  
8D4V Pumps – 10" Piping  
10" / 12" / 14" Suctions  
10" / 12" Discharge  
July, 2012

